



TECHNICAL CATALOG

Sandwich panels with the

- PIR core
- EPS core
- mineral wool core



TABLE OF CONTENTS

INTRODUCTION

ABOUT THE PRODUCT

Sandwich panel structure	7
Sandwich panel applications	8
Paneltech sandwich panel nomenclature and types	9
Available profilation types	10
Available RAL colors	12
Transport and storage recommendations.....	16
Installation recommendations	18
Protective coatings of steel facings	24

SANDWICH PANEL TECHNICAL DATA

Technical product cards	27
PWPIR-S.....	28
PWPIR-S LITE.....	30
PWPIR-SU.....	32
PWPIR-CH.....	34
PWPIR-D.....	36
PWPIR-D LITE	38
PWW-S	40
PWW-S LITE	42
PWW-SU	44
PWW-D	46
PWS-S	48
PWS-D.....	50

DRAWINGS OF TECHNICAL DETAILS

Wall panels	56
Coldroom panels	74
Roof panels	86

INTRODUCTION

Founded in 1989, Paneltech has been developing high-end products for the Polish construction industry. For over 30 years, Paneltech has combined reliability and highest product quality with timely services and deliveries. We have achieved this by employing our extensive experience and investing in the development of state of the art process lines. This is why, today, we are proud to say that we are one of the leaders on the Polish market of sandwich panels. We have received the support and trust of many clients, both in and outside the country. Our products are exported to nearly 30 countries from all over the world.

Paneltech offers the modern and comprehensive Light Cladding System with sandwich panels. Our regular offer includes the following sandwich panels:

- with the polyurethane PIR core,
- with the EPS core,
- with the mineral wool core.

Paneltech has its own machine park, research laboratory and the experienced quality control department thank to which manufactures itself highest-quality sandwich panels, industrial doors and EPS. Apart from these, Paneltech offers also facade cassettes, PIR SOFT LE insulation panels, EPS profiles, EPS roofing paper, XPS, aluminum and PVC joinery, stainless steel products and Hormann gates and reloading systems.

Our offer also includes specialist general contracting for industrial and agricultural facilities, along with the installation of insulated sandwich panels and cold room doors.



ABOUT THE PRODUCT

SANDWICH PANEL STRUCTURE

The Paneltech sandwich panel is a modern building material composed of two profiled facings made of varnished, galvanized steel sheets and an insulating core placed between them, made of rigid PIR foam, mineral wool or EPS.

The steel facing is made of steel sheet of 0.4 to 0.6 mm thickness, covered with organic protective coatings, both sides galvanized, which complies with the requirements of PN-EN 10346. The standard panel coating is finished with 25 µm thick polyester varnish, which guarantees a 15 - 20-year period of exploitation. Other coating materials, intended for internal and external facings exposed to aggressive environments are also available. To increase their stiffness and aesthetics, facings receive their characteristic profiling, available in several patterns. Panel joints are shaped to guarantee high tightness, ease of installation and the possibility of application additional sealing mass during installation, as to prevent the infiltration of gases and improving the panel's water-tightness properties.

The core of the panel is made of an insulating and structural layer which, depending on the material used, offers different physical and mechanical properties. Polyurethane-core panels (PIR) are characterized by very good thermal insulation properties, mechanical strength, as well as very high fire resistance properties. Panels with a mineral wool core have very good fire resistance properties. In turn, EPS-core panels are characterized by very good thermal insulation properties and are lighter, compared to other panels.

A sandwich panel cladding is not only an excellent thermal insulation, but also provides protection against weather conditions. Paneltech sandwich panels are offered in four types, i.e. wall panels with visible joints, wall panels with hidden joints, roof panels and coldroom panels with various thicknesses and colors, offering wide range of applications in the construction industry, both in typical and in innovative investments. Our panels are manufactured in various lengths, from 2.00 to 16.00 m and are custom-cut in a production process at a straight angle. Selecting the finishing color of the facing, the possible heating of the cladding by sun rays should always be considered as it can entail additional effects which can potentially change the load-bearing properties and the aesthetics of the product. More information about on panel parameters, available facing profiles, colors and coatings, can be found in the following catalog.

The technical documentation for the panels was drawn up in accordance with PN - EN 14509. Tests of the sandwich panels were carried out in renowned laboratories, such as the Building Research Institute, Fire Research Department in Warsaw, notification number 1488, in the Fires Batizovce Slovakia Research Facility, notification number 1396 and others. Based on the results of these tests, Paneltech as the producer using conformity assessment system No. 3, issued the declarations of performances in accordance with European norm and labeled it with CE mark.

SANDWICH PANEL CROSS-SECTION

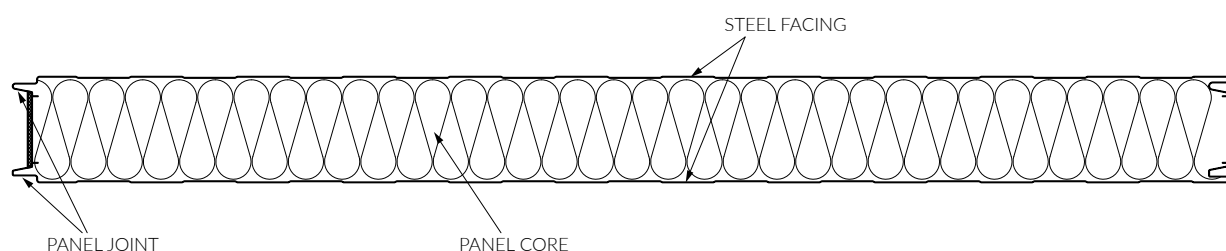

SANDWICH PANEL APPLICATIONS

Paneltech sandwich panels can be used to build such partitions as: external walls, internal walls, ceilings and roofs. They are widely applied in the construction of, among others:

- industrial production, commercial and storage halls,
- office and service complexes,
- containers,
- agricultural and food industry facilities,
- coldrooms and freezerrooms,
- roofing.

Sandwich panels are high-quality, light and durable structural elements. The most prominent advantages of self-supporting sandwich panels are:

- high mechanical strength,
- excellent thermal insulation properties,
- high tightness of wall and roof panel joints against heavy rain,
- high air and vapor tightness of wall and roof panel joints,
- easy and quick installation,
- proportionally low investment cost, compared with classic building methods,
- high aesthetics and diversity of facing colors and textures.

Sandwich panels should meet the technical parameters of the building project, and should be selected according to their:

- intended purpose (wall, roof, lock type),
- thermal insulation properties (U_c),
- fire resistance parameters (EI, not spreading the fire, Broof)
- mechanical strength,
- anti-corrosive properties of the facing,
- other (cladding type, color, module, aesthetics).

Our wide assortment of panel thicknesses and core types fulfills the requirements of current construction regulations, for instance, the U_c thermal transfer coefficient for buildings with room temperature of $t \geq 16^\circ\text{C}$ is max $0.20 \text{ W/m}^2\text{K}$ for external walls and max $0.15 \text{ W/m}^2\text{K}$ for roofs. Until 01.01.2017, these were, respectively 0.25 and 0.20 and until 31.12.2020, these were, respectively 0.23 and 0.18 .

Panels used in food industry facilities, for orientation purposes it can be assumed that the minimal thickness of the PIR-CH panel in a freezerroom relative to a ΔT temperature difference between the temperatures inside and outside the freezerroom, maintaining the recommended thermal stream density of up to 10 W/m^2 is:

- for $\Delta T = 50^\circ\text{C}$ - 120 mm
- for $\Delta T = 70^\circ\text{C}$ - 160 mm
- for $\Delta T = 80^\circ\text{C}$ - 180 mm
- for $\Delta T = 90^\circ\text{C}$ - 200 mm

Wall panels can be installed both vertically and horizontally. Construction of the roof panels let them to be installed on roofs with a minimum slope 5%, when the panel is the one element from the eaves to the ridge, and there is a minimum slope 9%, when the panels are connected in length by transverse joint (the length of the slope is greater than the recommended production length of the panel).

We know the needs and the requirements of our clients, which is why we can provide complex consultancy and technical support services devoted to light cladding systems. We have manufactured sandwich panels for more than 25 years. In this time, we have been able to develop an expert and experienced quality control department, and obtain an ISO certificate in confirmation of our excellent quality.

PANELTECH SANDWICH PANEL NOMENCLATURE AND TYPES

Paneltech sandwich panels are marked to the according scheme:

PWPIR-S 100.1130 0,5/0,4 SP25/SP25 9002/9002 MF/L

PW	PIR	S	100	1130	0,5/0,4	SP25/SP25	9002/9002	MF/L
commercial name	panel core	type	thickness	modular width	ext./int. facing thickness	ext./int. facing	ext./int. color	profile

Panels are available with three core types: polyurethane (PIR), EPS (PWS) and with mineral wool (PWW).

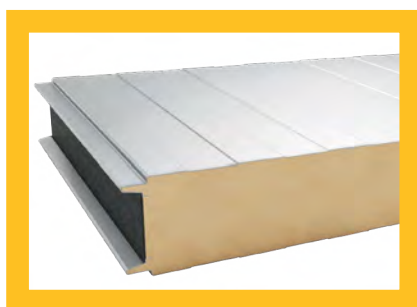

polyurethane core (PIR)

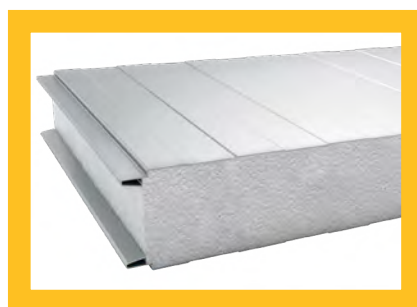

EPS core (PWS)

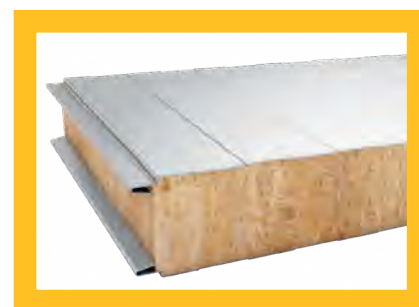

mineral wool core (PWW)

OUR PRODUCT OFFER INCLUDES THE FOLLOWING SANDWICH PANELS:



wall sandwich panels with visible joints

PWPIR-S, PWPIR-S LITE, PWW-S, PWW-S LITE, PWS-S



wall sandwich panels with hidden joints

PWPIR-SU, PWW-SU



coldroom sandwich panels

PWPIR-CH



roof sandwich panels

PWPIR-D, PWPIR-D LITE, PWW-D, PWS-D

AVAILABLE PROFILATION TYPES

The purpose of sandwich panel facing profilation is to improve the aesthetics of the panel and increase its stiffness. Depending on the panel type, different profilation types are available.

Profilation depth is ca. 1 mm. The exception to this is the external roof facing which has an individual trapezoidal T profilation of ca. 2 mm in total depth.

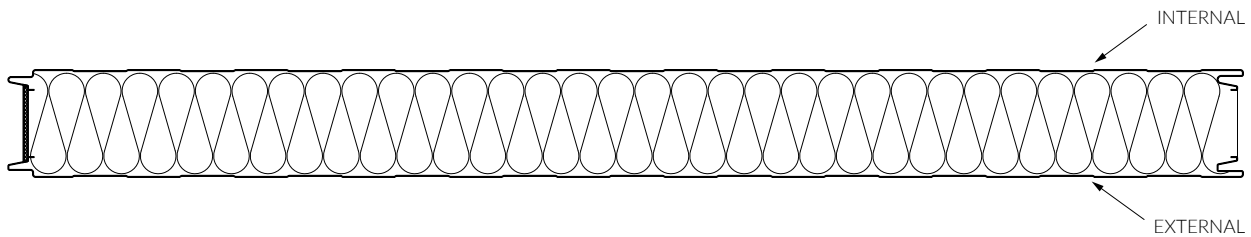

AVAILABLE EXTERNAL PROFILATION :

L	linear
MF	microwave
ML	microlinear
MR	microgroove ²⁾
G	smooth ¹⁾
C	carbon ³⁾
T	trapezoidal (for roof panels only)

AVAILABLE INTERNAL PROFILATION:

L	linear
R	groove ¹⁾
G	smooth ¹⁾

¹⁾ facings with the G - smooth or R - groove profiles can include microwaves, which affect the appearance of the product classified as compliant with the requirements of EN 14509, annex D

²⁾ applies to Paneltech sandwich panels with PIR cores. For more information concerning MR microgroove profilation, see the technical product cards

³⁾ applies to Paneltech sandwich panels with PIR cores.

L - LINEAR

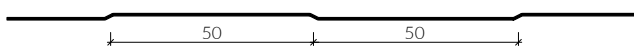

MF - MICROWAVE

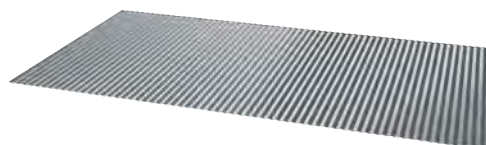

ML - MIKROLINEAR

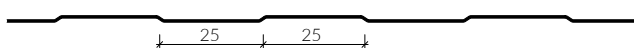

R - GROOVE

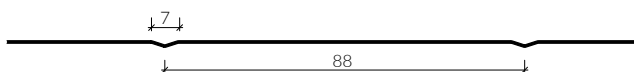

MR - MICROGROOVE

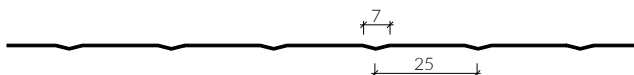

G - SMOOTH



T - TRAPEZOIDAL

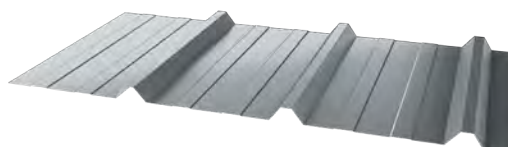

C - CARBON*

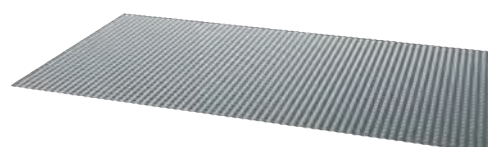

*MF profilation in two directions at 90°.

AVAILABLE RAL COLORS

All external Paneltech sandwich panel facings are available in a wide palette of colors matching the RAL color standard markings. The offer of SP25 polyester facings was divided into standard, typical and untypical. The inventory of the most popular standard colors are kept at a level which guarantees the complete and timely processing of all orders. Typical colors supplement the basic color palette. However, despite their high availability, they can extend the period to complete orders and can involve additional charges. At individual requests, we can provide panels with untypical colors. Atypical colors are however offered at individually approved commercial conditions.

The color of the external facing influences the self-heating temperature of the panel surface, when exposed to sun rays, which can result in thermal expansion properties, which, in turn, affect the strength of both the panel and the facing. There are three groups of sandwich panel facing colors:
 Group I – very bright colors,
 Group II - bright colors,
 Group III – dark colors.

STANDARD COLORS

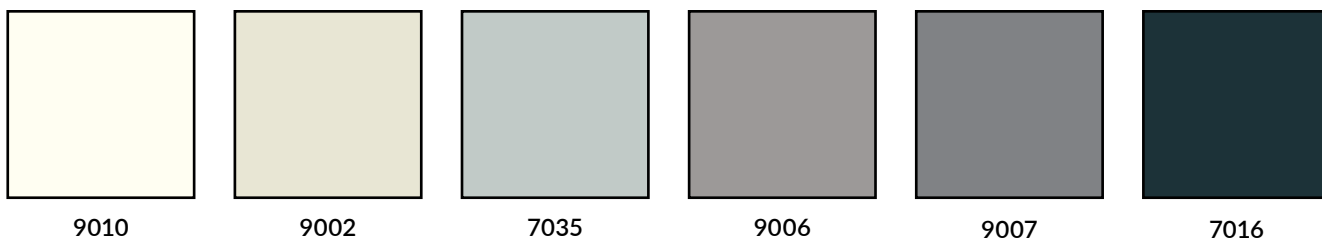

TYPICAL COLORS

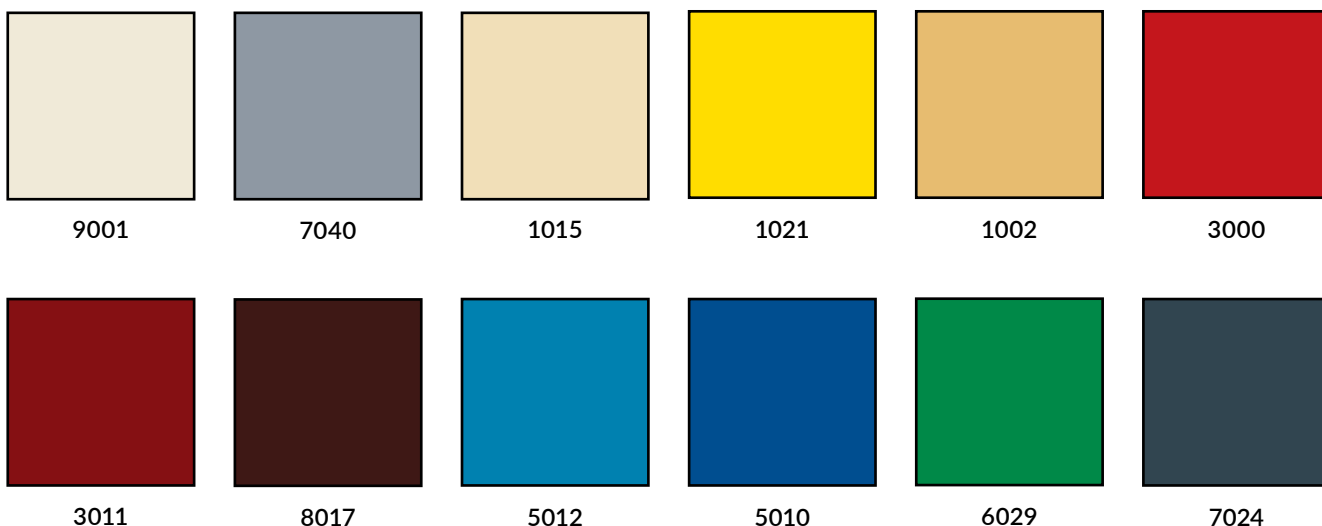

The colors presented in the catalog are for reference only. Steel sheet tones may differ, depending on the material batch and the manufacturer. Paneltech Sp. z o.o. therefore admits the possibility of occurrence of color differences between the samples presented and the colors of materials supplied.

We recommend using very bright and bright colors (color groups I and II). Further we strongly advise against using wall panels with dark facing in multiple-span systems, due to the possible facing deformations. Dark sandwich panel facings have very good heat absorption properties, which can cause local facing deformations in periods of high insolation. Therefore, panels should have possibility for the thermal movements and their length should be limited. This effect

does not have influence on the performance characteristics of the panel. The general rule is that panel length should be selected depending on the color and the technological possibilities, as presented in the table below.

Internal sandwich panel facings are available in two basic colors: RAL 9002 and 9010. Other colors available on request.

COLOR TABLE FOR SANDWICH PANEL FACINGS

Color group / surface self-heating in the summer	Color number as per the RAL system	Reflectance coefficient for the RG facing [%]
I – very bright colors, temperature up to 55°C	1015, 1018, 7035, 9001, 9002, 9010	75-90
II - bright colors, temperature up to 65°C	1002, 1007, 1021, 2008, 2011, 5012, 6018, 9006, 7040	40-74
III – dark colors, temperature up to 80°C	3000, 3005, 3011, 3016, 5010, 5011, 6003, 6005, 6011, 6029, 7016, 7024, 8004, 8017, 9007	8-39

Any colors which are not listed above should be qualified in an applicable color group based on the reflectance coefficient value.

TABLE OF RECOMMENDED PANEL LENGTHS, DEPENDING ON THE COLOR OF THE FACING AND THE TECHNOLOGICAL POSSIBILITIES

PANELTECH sandwich panel type	thickness [mm]	group I - v. bright [m]	group II - bright [m]	group III - dark [m]
PWPIR-S, PWPIR-S LITE	40 ÷ 60	2 ÷ 10	2 ÷ 9	2 ÷ 7
PWPIR-S , PWPIR-S LITE	80 ÷ 120	2 ÷ 15,8	2 ÷ 9	2 ÷ 7
PWPIR-SU	60	2 ÷ 10	2 ÷ 9	2 ÷ 7
PWPIR-SU	80 ÷ 120	2 ÷ 15,8	2 ÷ 9	2 ÷ 7
PWPIR-CH	120 ÷ 200	2 ÷ 15,8	2 ÷ 9	2 ÷ 7
PWPIR-D, PWPIR-D LITE	40 ÷ 160	2 ÷ 16	2 ÷ 9	2 ÷ 7
PWS-S	50 ÷ 200	2 ÷ 10	2 ÷ 7	2 ÷ 7
PWS-D	80 ÷ 200	2 ÷ 10	2 ÷ 7	2 ÷ 7
PWW-S, PWW-S LITE	60 ÷ 160	2 ÷ 10	2 ÷ 7	2 ÷ 7
PWW-S, PWW-S LITE	180 ÷ 200	2 ÷ 7	2 ÷ 7	2 ÷ 7
PWW-SU	80 ÷ 160	2 ÷ 10	2 ÷ 7	2 ÷ 7
PWW-SU	180 ÷ 200	2 ÷ 7	2 ÷ 7	2 ÷ 7
PWW-D	80 ÷ 160	2 ÷ 10	2 ÷ 7	2 ÷ 7
PWW-D	180 ÷ 200	2 ÷ 7	2 ÷ 7	2 ÷ 7

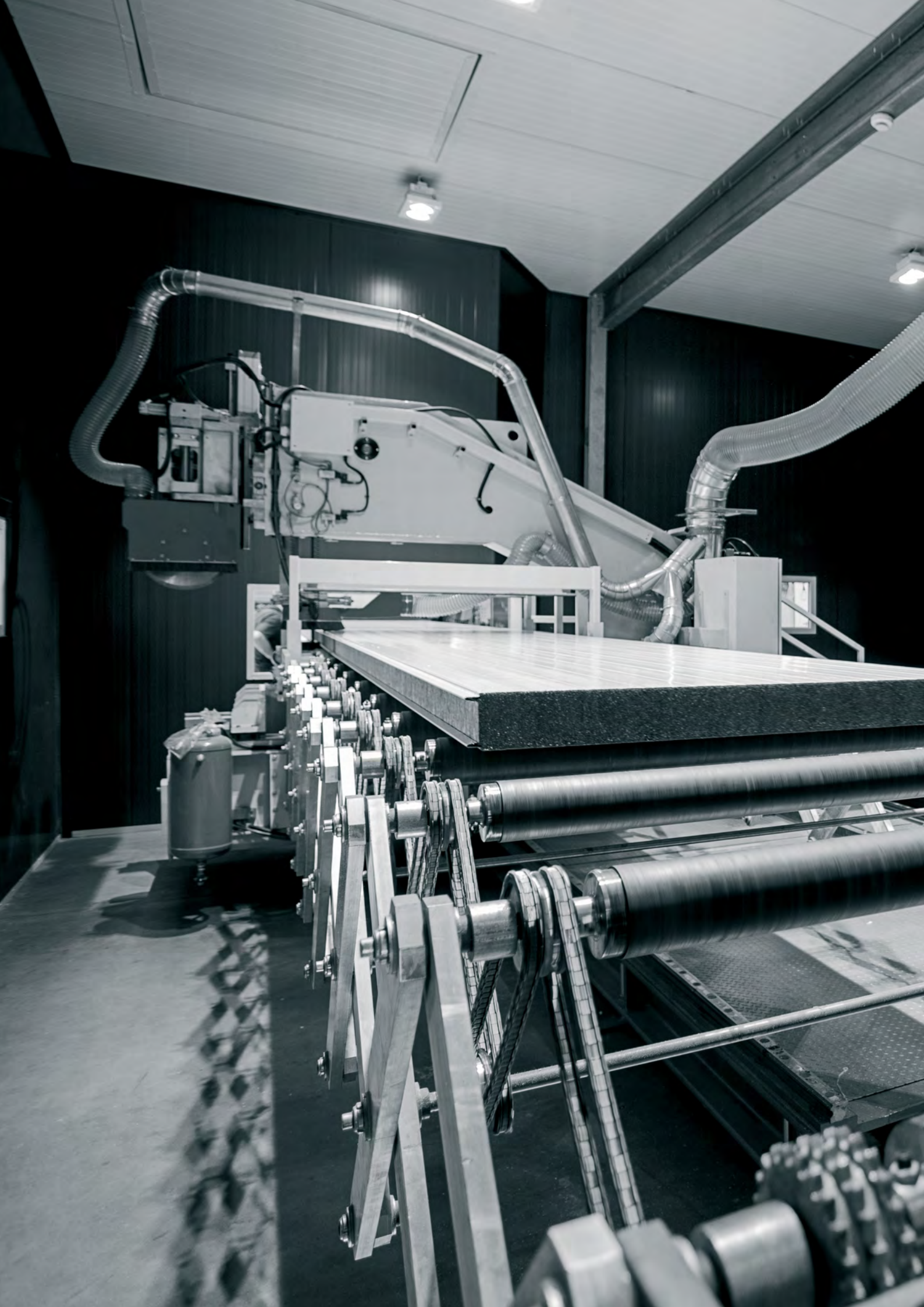



TRANSPORT AND STORAGE RECOMMENDATIONS

PACKING

Sandwich panels are packed during production process into packages laid on wooden pallets (mineral wool core panels) or on styrofoam bases, and wrapped in protective foil. Two documents are enclosed to each package: the product label and the unloading manual. The maximum pack dimensions are 16 x 1.20 x 1.30 m (LxWxH).

TRANSPORT TO THE CONSTRUCTION SITE

The panel delivery date will be set after considering all stages of the production process. The number of panels depends on the type and thickness. 2-3 packet layers can be transported, depending on the panel type. By standard, panels are transported by trucks: the width of flat cargo space is 2.40 m, height is 2,65 m, the cargo should be loaded on both sides and fastened using tie down straps. Individual packages should be secured using wooden or plastic pads. Packages must be loaded onto cars by Paneltech staff, with the active participation of the driver, who is responsible for fixing and securing the panels to the car and periodically controlling the cargo during transport.

UNLOADING AT THE CONSTRUCTION SITE

Unloading should be carried out for products in original, factory packaging only, using cranes and handling devices intended for horizontal lifting. Crane devices or forklifts are recommended for lifting packets. Packets of 6 m and more should be transported using two forklifts or using tie down straps and an H cross-beam, preventing the straps from clamping down on the packet. With any reservations to the cargo, the recipient or the carrier are obligated to include place a suitable note on the delivery note and on the shipping document.

STACKING AND STORAGE OF SANDWICH PANELS

Packages on factory bases should be stored on an even, slightly inclined surface, and should be secured against the weather conditions and protected from soiling. Time of storage in factory packaging should not exceeded 4 weeks, and, exposed to weather conditions, protective foil coatings should be unwrapped at +5 to 60 °C up to 2 weeks.

PWPIR SANDWICH PANEL CONTENT IN A PACKET

	S	SU	CH	D
Thickness [mm]	maximum number of panels in a package [pcs.]			
40	14	-	-	18
60	18	18	-	14
80	14	14	-	10
90	-	-	-	10
100	11	11	-	8
120	9	9	9	8
145	-	-	-	6
160	-	-	7	6
180	-	-	6	-
200	-	-	5	-

MINERAL WOOL CORE SANDWICH PANEL CONTENT IN A PACKET

	S	SU	D
Thickness [mm]	Maximum number of panels in a package [pcs.]		
60	17	17	-
80	13	13	10
100	10	10	8
120	9	9	6
140	7	7	6
150	7	7	6
160	6	6	6
180	6	6	4
200	5	5	-

EPS CORE SANDWICH PANEL CONTENT IN A PACKET

	S	D
Thickness [mm]	Maximum number of panels in a package [pcs.]	
50	22	-
80	14	10
100	11	8
120	9	8
150	7	6
200	5	5

1. Quantity of panels in the packages may differ from the above given due to the optimal use of loading height – 2,65 m.
2. A maximum of two full packages can be loaded onto a truck.
3. Non-standard packaging is possible on client's request, after the technological possibilities are approved by a Paneltech Customer Service employee.

INSTALLATION RECOMMENDATIONS

PREPARATORY WORKS

Sandwich panels, as cladding elements, are fixed to structures in precisely determined and prepared points. This contributes to producing a highly aesthetic effect and prevents steel facings from deforming. Before proceeding to any installation works, check for: the accuracy of construction of the supporting structure and its compliance with the design, the maximum permissible support span (in accordance with Paneltech characteristic loading tables) and the condition of the panel facing. Sandwich panels with visible joints (PWPIR-S) have protective foil with arrows on the edges. The arrowhead points to the external facing of the panel.

PANEL CUTTING

Sandwich panels are produced to a specific length. All cutting works should be carried out using fine-tooth sawing machines or circular saws for metal. Angle grinders or any other tools generating high temperatures when cutting mustn't be used, as they can destroy the organic coatings protecting sheet metal against corrosion. After cutting the panels, their surface should be cleaned out of metal filings.

SELECTION OF FASTENERS

By standard, sandwich panels are fixed to structures using steel fasteners passing through two steel facings of the panel. Location of the fasteners should be set in accordance with the current Paneltech technical catalog. The number of fasteners, the structural span and the width of the supports are defined in panel characteristic loading tables. For instance: the PWPIR-S 120 0.5/0.5 very bright panel (group I), installed in the single-span layout and with characteristic wind loading of $\pm 0.6 \text{ kN/m}^2$ should be fixed using three fasteners to each support of 40 mm in width and with a span of up to 7.50 m.

The fasteners should be selected on the basis of:

- the type and thickness of the construction, to which the sandwich panel is fixed,
- the type and the thickness of the sandwich panel in the point of the mounting,
- the mechanical, physical and chemical properties of the fastener.

Fasteners selection depending on the type and thickness of the construction, to which the sandwich panel is fixed:

- when the panel is fastened to steel profiles using a self-drilling screws in a single technological cycle, in which the hole is drilled and threaded (e.g. when installing on thin-wall, steel profiles using fasteners with a drill up to 6 mm and with a loose thread), when the panel is fastened to hot-rolled steel profiles of 3 to 16 mm in thickness, using fasteners with a 12 or 16 mm drill and a tight thread,

- fastening to steel profiles with a thickness of 6 mm or more using self-drilling fasteners in two technological cycles, by making a pilot hole in the sandwich panel and structure and inserting the fastener into the pilot hole, while simultaneously threading it into the structural element,
- when the panel is fastened to wooden profiles using a self-tapping screws in a single technological cycle, during which the hole is drilled and threaded. When panels are installed on hard wood, a preliminary hole must be drilled,
- when the panel is directly fastened to concrete elements using a self-tapping screws in two technological cycles, by executing a preliminary hole in the sandwich panel and in the construction, and by placing the fastener in the preliminary hole while threading the other hole,
- when the panel is fastened to concrete elements using a self-drilling screws with a polyamide plug in two technological cycles, by drilling a hole in the sandwich panel and in the construction, and by placing a polyamide plug and the fastener in the element of the construction.

Fasteners selection depends on its mechanical, physical and chemical properties:

- the characteristic tensile strength of the fastener with 19 mm metal washer and EPDM gasket should be 2.20 kN or higher (the calculated strength should be 1.65 kN or higher),
- fasteners made of stainless steel or polyamide fasteners with screws made of carbon galvanized steel are characterized by lower thermal conductivity,
- fasteners made of stainless steel or polyamide fasteners with screws made of carbon galvanized steel are characterized by higher anti-corrosive properties.

GUIDELINES FOR PROPER FASTENERS ASSEMBLY

- specialized electric tools should be used for installation,
- the diameter and the depth of the preliminary hole in the substrate should meet the requirements of the fasteners manufacturer,
- each fastener should be installed perpendicularly to the construction,
- after the fastener is installed, the EPDM gasket from the washer should seal the connection – the fastener must not be screwed in too tight or too loose in order not to damage the washer,
- the minimum distance of the fastener from the cut edge of the panel should be 30 mm,
- use self-drilling $\text{Ø}4.8$ screws with washers with EPDM gaskets to connect the upper facings of roof panels,
- after installing all fasteners, clean the surface of the panel to remove all metal filings.

PANEL TRANSPORT AT THE CONSTRUCTION SITE

Use vacuum lifters (e.g. the Viavac vacuum lifter) or other methods which do not cause bending of the panels. Vacuum lifter should be selected according to the panel type.

ASSEMBLY ELEMENTS AND FLASHINGS

The Paneltech Light Cladding System requires the use of supplementary elements, custom-designed for roof panels and for panels with hidden joints. The correct installation of roof panels (type D) in the ridge requires the use of a UD42 roof seal, the flashing No. 102 roof ridge one for each panel. For closing of the trapeze core the Z42 roof end cap (3 pcs. per panel) should be used.

Using the SU washer is recommended in order to install wall panels with hidden joints to the construction (type SU).

Flashings are used as aesthetic finishing to a sandwich panel cladding. Plus, they provide additional protection against the weather. Drawings of standard flashings are presented in a separate catalog. The shape of individual elements can be modified, keeping the rules of building art. Self-drilling Ø4.2 screws with flat heads, self-drilling Ø4.8 screws with a washer with an EPDM gasket (e.g. roof elements), Ø4.0 blind rivets are used to install the flashings.

To obtain higher water-tightness properties of the cladding, sealing mass or tape can be applied in between flashings and panel facings or other cladding elements. There is no possibility during production process to make additional panels cutting, such as: cutting the window/doors/gate openings, cutting slants, cutting the panels on specific width. Above mentioned are carried out at the building site by assembly company.

Sealant material should meet project design requirements, i.a. thermal insulation, tightness and fir resistance.

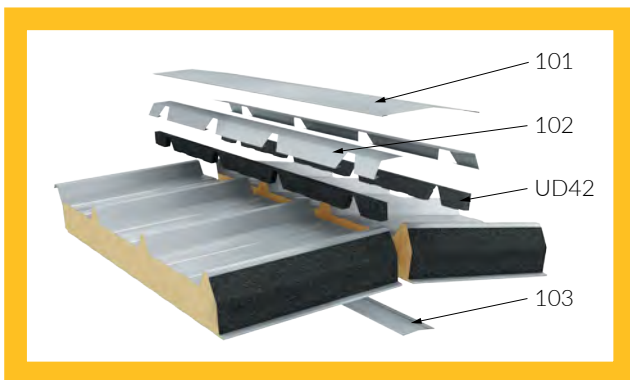

panel joint at the ridge

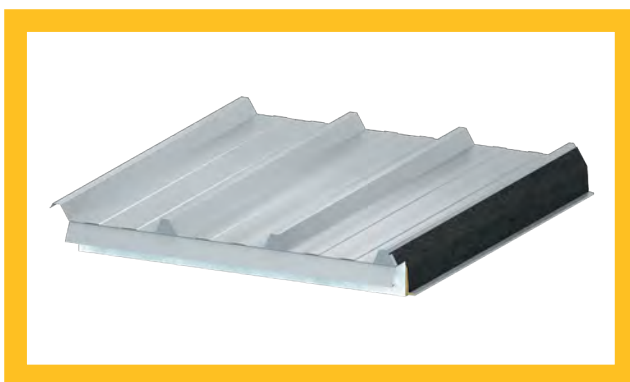
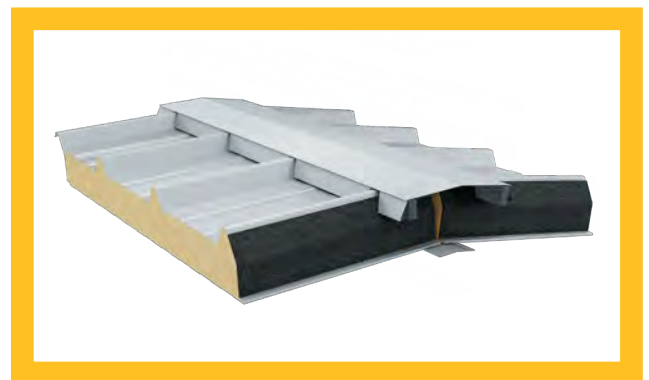

guttered eaves

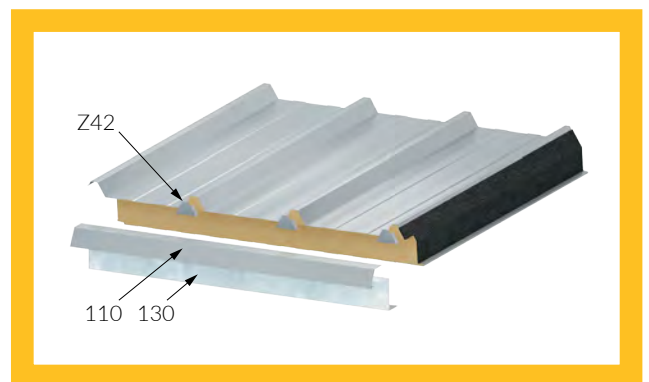

PANELS ASSEMBLY

Installation of the panels should be carried out according to the project design, the Sandwich Panel Assembly Instruction (appendix 3 to the General Sales Conditions, available at www.paneltech.pl), drawings from the Paneltech Technical Catalog and applicable health and safety regulations. The designer of the construction is in charge of applying specific technical solutions in the light cladding systems made of sandwich panels. Technical solutions deviating from those presented above are permitted, provided that the general rules of the building art are kept.

When laying panels symmetrically (type S, CH), make sure not to confuse the external side with the internal one, since this will result in mismatched facing tones on the facade. Taking panels from different packages and different production periods to execute the cladding of a single wall can have a similar result.

The structure of the panel joint allows for applying a plastic mass at the stage of installation in between the steel parts of the lock. Depending on the panel type, its application and the type of the mass, the purpose of the seal is to limit air, water permeation and secure the desired fire resistance and hygiene parameters. Detailed information was included next to the panel types. During installation, make sure to maintain the continuity of thermal insulation at the joint of insulating cores and fill free spaces with polyurethane foam or an expanding seal. To even out the pressure between panels, use dedicated canvas belts with buckles. The opening in the lock of the steel facing should fit in the tolerance for a given panel type. Keep an dilatation joint between individual facings of ca. 10 ÷ 20 mm at the joint of cutted panel edges and around walls and roofs. The roof panel installation method is presented in drawings in this catalog.

Suitable footwear which does not scratch the panel surface should be worn during installation works. All sealing works must be carried out at 4°C and higher. Installation should not be carried out in adverse weather conditions, such as rain, snow, icing, strong wind, limited visibility, and when ambient temperatures exceed 28°C, or when the panels are very hot.

SANDWICH PANELS OVERLAP CUTTING

The production line enables overlap cutting with a length of 50 to 250 mm (in 10 mm increments). The overlap cut of roof panels is made through the entire thickness of the panel (inner facing + core). It is also possible to perform a "clean overlap cut" on roof panels using a film tape (applied to the outer facing on the core side) to allow easier separation of the core from the outer facing. A summary table presents the minimum panel lengths for which overlap cutting can be performed:

thickness of the roof panel [mm]	minimum length [m] of the roof sandwich panel for the overlap cutting:	
	50 ÷ 100 mm without foil	clean (with foil)
40 ÷ 80	2,8	4,0
100	2,5	4,0
120	2,2	3,5
145 ÷ 200	2,0	3,5

The overlap cutting of PWPIR-CH wall panels is performed to a depth of 20 to 100 mm, leaving at least 30 mm of the panel's thickness intact. The minimum panel length with overlap cutting is 2.2 m.

The final overlap cut is obtained by removing the trimmed part of the facing together with the cut section of the insulating core. This operation should be carried out on-site before installation.

Paneltech produces both right-side (PP) and left-side (PL) overlap cuts. The method for determining the type of overlap cut is presented later in the catalogue.

MARKING AND EXAMPLES OF OVERLAP CUTTINGS

Marking of roof panels, is supplemented with additional information about direction and length of the overlap cutting. No additional information means that there is no overlap cutting.

Example: PWPIR-D 120.1050 0,5/0,4 SP25/SP25 9002/9002 T/L PP50, where:

PP – right overlap cut

PL – left overlap cut

50 – 250 – length of the overlap cutting in mm

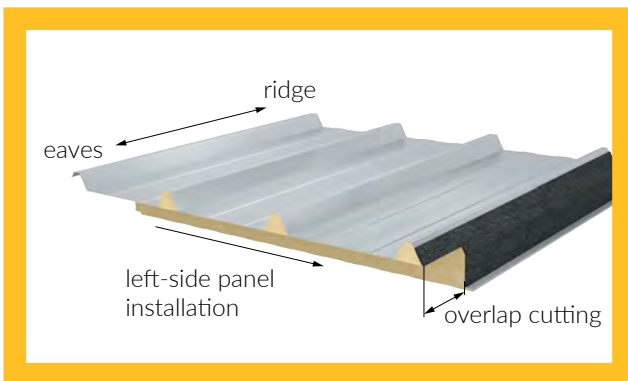

left-hand edge cut of a roof panel

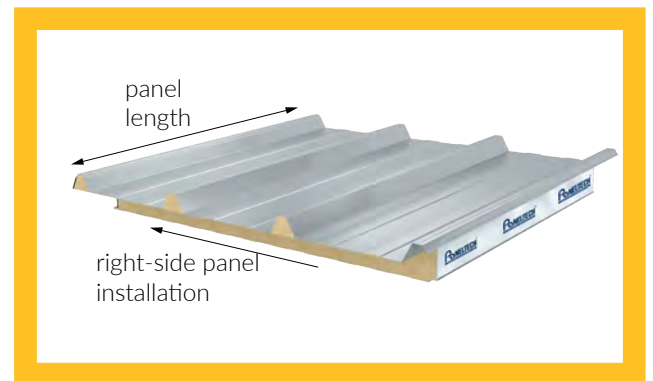

right-hand edge cut of a roof panel

Marking of wall panels PWPIR-CH longer than 2200mm may be supplemented with additional information about direction and length of overlap cut. No additional information means that a panel is without overlap.

Example: PWPIR-CH 200.1130 0,5/0,5 SP25/SP25 9002/9002 MF/L PP200x100, where:

PP – right-hand overlap cut (overlap cut from the right side of panel, when looking from tongue side at a panel arranged with internal side upwards)

PL – left-hand overlap cut (overlap cut from the left side of panel, when looking from tongue side at a panel arranged with internal side upwards)

first number - length of overlap cut within 50÷250mm

second number - depth of overlap cut within 20÷100mm

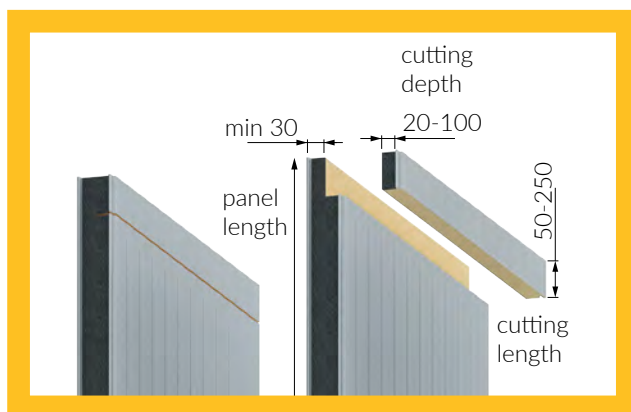

wall panel overlap cutting.





ABUS 101

91004
Rachy
Mittel
200-745

PROTECTIVE COATINGS OF STEEL FACINGS

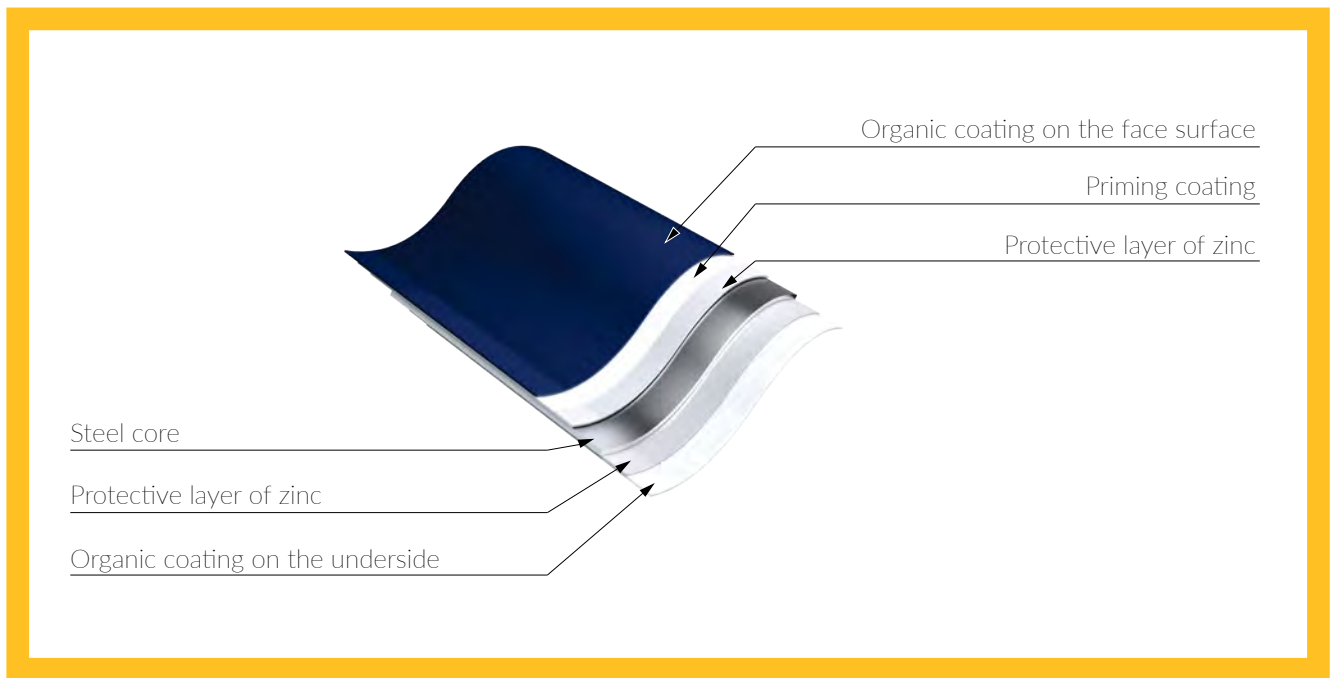

coating diagram

SP25

Universal polyester coating for indoor and outdoor applications in low and standard aggressiveness environments. Application: outdoor - up to corrosivity category C3; indoor - up to C1, A1²⁾.

PU

Polyurethane coating for standard, aggressive and demanding environments. It is characterized by high resistance to corrosion and UV radiation. Recommended in facilities where color fastness and aesthetics are important. Application: exterior - for C5¹⁾; interior - for C5¹⁾ and A4¹⁾.

FARM

The coating is designed for the interiors of agricultural and livestock facilities, such as piggeries, poultry houses and grain stores. Adapted to work in aggressive environments. Application: interior - up to C3, A1.

FOOD SAFE

Interior coating, approved for food contact. Easy to clean, resistant to cleaning agents. Application: indoor - up to A5¹⁾.

SPECIAL

Coatings for extreme environmental conditions, including high corrosivity and intensive use. Application: outdoor - up to C5¹⁾; indoor - up to C5¹⁾ and A5¹⁾.

TABLE OF COATING PROPERTIES

NAME	TYPE	THK. [µm]	CORROSION RESISTANCE	APPLICATION	SURFACE FINISHING ²⁾
SP25	polyester	25	C3 / C1, A1 ³⁾	common	smooth
PU	polyurethane	35-60	conditionally C5 ¹⁾ , A4 ¹⁾	environment with increased corrosion class	smooth with shine
FARM	polyester	35	conditionally C3, A1	from inside of buildings (no UV-resistance), agricultural buildings, high resistance to ammonia	smooth
FOOD SAFE	PVC laminate	120	conditionally C5 ¹⁾ , A5 ¹⁾	from inside of buildings (no UV-resistance), premises with controlled environmental parameters: cold stores, clean rooms, e.g. meat processing plants	matt / grainy
special	polyvinyl chloride	200	conditionally C5 ¹⁾ , A5 ¹⁾	environment with high corrosion resistance class	scintilla finishing
	pvdf/polyurethane	40-65	conditionally C5 ¹⁾ , A5 ¹⁾	environment with high corrosion resistance class, high colour fastness	smooth

¹⁾ Organic coating is selected on the basis of its durability and application conditions. Coating selection is carried out through environmental assessment based on an environmental questionnaire completed by the Client, approved by the steel manufacturer and Paneltech.

²⁾ Applies to the standard warranty. It is possible to extend the warranty according to reference 1).

³⁾ C3 applies to the standard warranty for exterior cladding; C1, A1 applies to the standard warranty for interior cladding. It is possible to extend the warranty according to reference 1).



SANDWICH PANEL TECHNICAL DATA

SANDWICH PANEL TYPES

Paneltech offers sandwich panels in three core variants:

PWPIR / PWPIR LITE

The core of the panel is made of rigid polyurethane foam (PIR) that meets the requirements of the PN-EN 13165 standard, including dimensional stability and thermal insulation performance. Sandwich panels with a polyurethane foam core – PWPIR-S, PWPIR-S LITE, PWPIR-SU, PWPIR-CH, PWPIR-D and PWPIR-D LITE – are manufactured in accordance with the European standard PN-EN 14509

PWS

The core of this sandwich panel is made at the least of EPS 60, Paneltech production. Sandwich panels with EPS cores type PWS-S and PWS-D are manufactured in accordance with PN-EN 14509.

PWW / PWW LITE

The core of the panel is made of mineral wool supplied by leading wool insulation producers. Sandwich panels with mineral wool cores type PWW-S, PWW-S LITE, PWW-SU and PWW-D are manufactured in accordance with PN-EN 14509

Each core has its own performance characteristics and parameters. The core should be selected depending on the requirements and applications. For instance, the fire rating is an important factor, as a sandwich panel with a mineral wool core has reaction to fire class A2-s1,d0, which surpasses this of a sandwich panel with a polyurethane core, which has reaction to fire class B-s2,d0, or the sandwich panel with the EPS core - with an E class reaction to fire.

Depending on their shape and their intended purpose, Paneltech products are classified into sandwich panel families:

- wall panels with visible joints,
- wall panels with hidden joints,
- wall coldroom panels,
- roof panels.

TERM EXPLANATION

Fire resistance:

R	fire load capacity
E	fire integrity
I	fire insulation

Reaction to fire:

A2-s1, d0	non-combustible, hardly no smoke, no flaming droplets;
B-s1, d0	combustible, difficult to ignite, nearly no smoke, without flaming droplets;
E	combustible, easily ignited, unlimited smoking, self-extinguishing;
B _{roof} (t1)	fire-retardant roofing;

Outside corrosion categories:

C2	Rural areas with low corrosion classes
C3	Urban and industrial areas with low SO ₂ levels, with medium corrosion classes
C4	Industrial areas with moderate SO ₂ levels, with high corrosion classes
C5-I	Industrial areas with high SO ₂ levels, with very high corrosion classes

Internal corrosion categories:

C1	Heated buildings with a clean atmosphere, such as offices, stores, schools, hotels.
C2	Unheated buildings where condensation can occur, such as warehouses, apartments, sports halls.
C3	Production rooms with high humidity and some air pollution, such as food plants, laundries, breweries, dairies.
C4	Rooms with a high frequency of condensation and pollution from industrial processes, such as industrial plants, chemical plants, swimming pools, shipyards.
C5	Rooms with almost continuous condensation and high pollution.

Internal environment categories:

A1	Non-aggressive environment, occasional condensation, e.g. dry storage buildings.
A2	Hardly aggressive environment, occasional condensation, e.g. coldrooms, supermarkets.
A3	Moderately aggressive environment, occasional condensation, e.g. food processing and industrial buildings with dry processes carried out.
A4	Very aggressive environment, occasional condensation, e.g. industrial buildings with wet processes carried out, swimming pools.
A5	Strongly aggressive environment, occasional condensation, e.g. wet food processing (fish processing).

Minimum Production Quantity (MPQ) is from 200m² up to 1000m² and depends on type and thickness of the panel. In order to verify production possibilities of specific order please contact our Customer Service or Sales Representative.

PWPIR-S

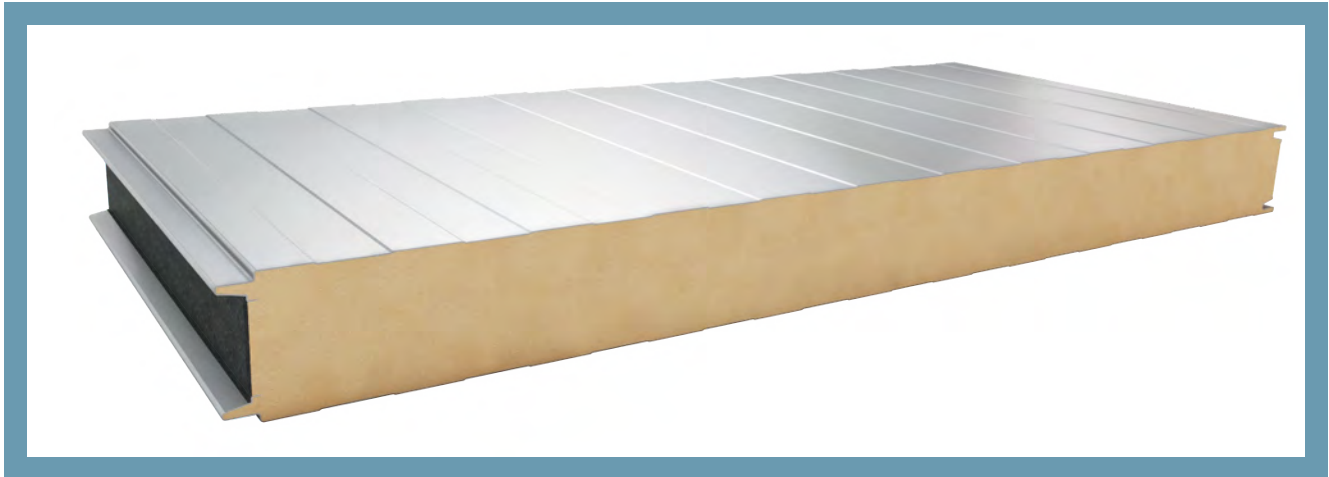

Panels connection scheme

APPLICATION

Wall sandwich panel with visible joint PWPIR-S is used to construct external walls and internal partitions in the single- or multiple-span shell structure.

The panel can be installed both vertically and horizontally. PWPIR-S panel is characterized by very good thermal insulation properties and strength, as well as very high fire resistance properties. The core of the panel comprises polyisocyanurate foam (PIR) of 40 kg/m³ in total density. PWPIR-S panel is compatible with wall panel with mineral wool core type PWW-S, PWW-S LITE and with wall panel with expanded polystyrene core type PWS-S.

AVAILABLE PROFILATION TYPES

EXTERNAL PROFILATION

- L** - LINEAR
- MF** - MICROWAVE
- ML** - MICROLINEAR
- G** - SMOOTH
- MR** - MICROGROOVE
- C** - CARBON

INTERNAL PROFILATION

- L** - LINEAR
- R** - GROOVE
- G** - SMOOTH

TABLE OF TECHNICAL PARAMETERS OF THE PWPIR-S PANELS

Parameter	Value				
thickness [mm]	40	60	80	100	120
modular width [mm]	1130, 1000 (optionally 1050) ¹⁾				
length ²⁾ [mm]	2000 ÷ 15800				
weight ³⁾ [kg/m ²]	9,9	10,7	11,5	12,3	13,1
heat transfer coefficient U _c [W/m ² K]	0,58	0,37	0,27	0,22	0,18
acoustic insulation Rw [dB]	26				
reaction to fire	B-s1,d0				
resistance to external fire ⁴⁾	NRO				
wall fire rating ⁵⁾	NPD	EI 15 (o ↔ i) ⁵⁾	EI 15 / EI 30 (o ↔ i) ⁵⁾	EI 30 (o ↔ i) ⁵⁾	
anti-corrosive protection	depending on the coating used ⁶⁾				
organic coatings	SP25, PU, AGRO, FOOD SAFE and other ⁶⁾				
external facing	galvanized steel 0,5 ÷ 0,6 mm ⁷⁾				
internal facing	galvanized steel 0,4 ÷ 0,6 mm ⁷⁾				
available profilation types	external facing L, ML, MR ⁸⁾ , G ⁹⁾ , C; internal facing L, R ⁹⁾ , G ⁹⁾				
insulating core	rigid foam of 40 kg/m ³ in total density and with enclosed PIR (polyisocyanurate) cells				
application	non-continuous application on external walls and as wall cladding, on the structural parts of walls and ceilings				
wall application layout	vertical or horizontal				

¹⁾ In order to verify the feasibility of a given order, please contact our Customer Service Department or Sales Representative.

²⁾ length depends on the color of the external facing and the thickness of the panel

³⁾ average weight of a sandwich panel with 0.5 mm outer facing, including product tolerance

⁴⁾ fire rating concerning the propagation of fire by the wall when the fire acts towards the outside. This property applies to the Polish territory only and is not CE-marked.

⁵⁾ detailed information (including panel layout and support spans) can be found in the General Terms and Conditions of Sale available at paneltech.pl.

⁶⁾ organic coat selected on the basis of durability and application conditions. Coat selection is carried out through environmental assessment and basing on an environmental questionnaire completed by the Client, approved by the steel manufacturer and Paneltech

⁷⁾ other steel types are selected according to application conditions and approved by Paneltech

⁸⁾ detailed information on the MR – microgroove profilation will be provided at individual request

⁹⁾ facings with the G – smooth or R – groove profiles can include microwaves, which affect the appearance of the product classified as compliant with the requirements of EN 14509, annex D.

MORE ABOUT PWPIR-S



CONTACT OUR REPRESENTATIVE



PWPIR-S LITE

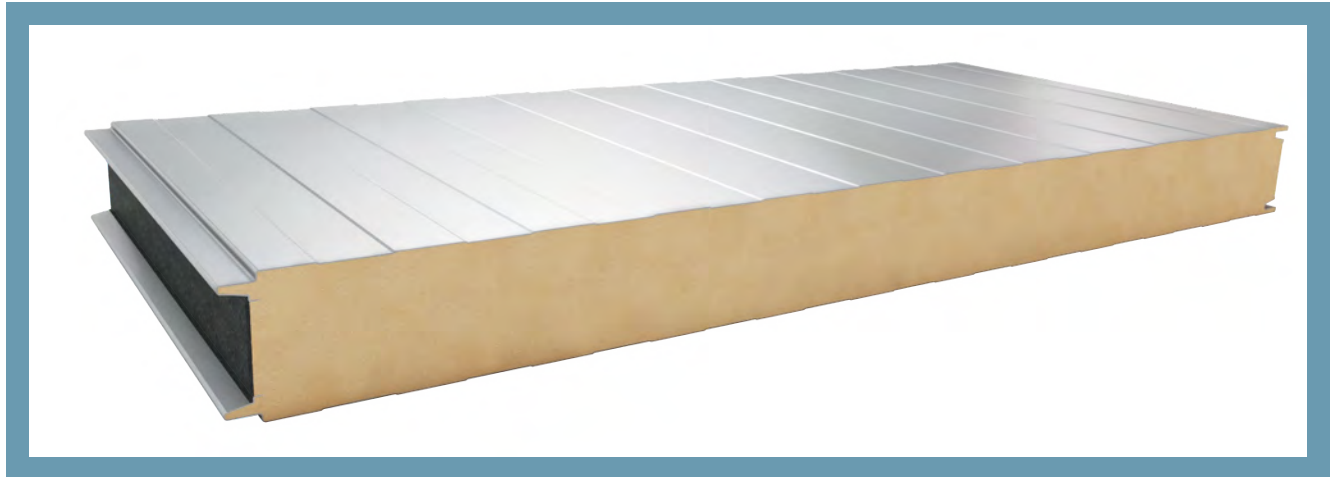

Panels connection scheme

APPLICATION

Sandwich wall panel with visible joint PWPIR-S LITE is used to construct external walls and internal partitions in the single-or multiple-span shell structure.

The panels can be installed both vertically and horizontally. Unlike PWPIR-S, its core consists of stiff polyisocyanurate foam (PIR) with a density of about 35 kg/m³. Despite a lower density, the panel is characterised by good thermal insulation and strength, however some micro-unevennesses are likely to occur on its surface.

Therefore it's not recommended to use the panels in facilities where high aesthetics is required. PWPIR-S LITE panels are compatible with polyisocyanurate core wall panels PWPIR-S, with mineral wool core type PWW-S, PWW-S LITE and with wall panels with expanded polystyrene core type PWS-S.

AVAILABLE PROFILATION TYPES

EXTERNAL PROFILATION

- L** - LINEAR
- MF** - MICROWAVE

INTERNAL PROFILATION

- L** - LINEAR

TABLE OF TECHNICAL PARAMETERS OF THE PWPIR-S LITE PANELS

Parameter	Value		
thickness [mm]	80	100	120
modular width [mm]	1130 (optionally 1000) ¹⁾		
length ²⁾ [mm]	2000 ÷ 15800		
weight ³⁾ [kg/m ²]	11,3	12,1	12,9
heat transfer coefficient U _c [W/m ² K]	0,28	0,22	0,19
acoustic insulation Rw [dB]	NPD		
reaction to fire	B-s1,d0		
resistance to external fire ⁴⁾	NRO		
wall fire rating ⁵⁾	NPD	EI 15 (o ↔ i) ⁵⁾	
anti-corrosive protection	depending on the coating used ⁶⁾		
organic coatings	SP25		
external facing	galvanized steel 0,5 mm ⁷⁾		
internal facing	galvanized steel 0,4 ÷ 0,5 mm ⁷⁾		
available profilation types	external facing L, MF; internal facing L		
insulating core	rigid foam of 35 kg/m ³ in total density and with enclosed PIR (polyisocyanurate) cells		
application	non-continuous application on external walls and as wall cladding, on the structural parts of walls and ceilings		
wall application layout	vertical or horizontal		

¹⁾ Minimum Production Quantity (MPQ) is 1000 m² and depends on thickness of the panel. In order to verify production possibilities of specific order please contact our Customer Service or Sales Representative.

²⁾ length depends on the color of the external facing and the thickness of the panel

³⁾ average weight of a sandwich panel with 0.5 mm outer facing, including product tolerance

⁴⁾ fire rating concerning the propagation of fire by the wall when the fire acts towards the outside. This property applies to the Polish territory only and is not CE-marked.

⁵⁾ detailed information (including panel layout and support spans) can be found in the General Terms and Conditions of Sale available at paneltech.pl.

⁶⁾ organic coat selected on the basis of durability and application conditions. Coat selection is carried out through environmental assessment and basing on an environmental questionnaire completed by the Client, approved by the steel manufacturer and Paneltech

⁷⁾ other steel types are selected according to application conditions and approved by Paneltech

MORE ABOUT PWPIR-S LITE



CONTACT OUR REPRESENTATIVE



PWPIR-SU

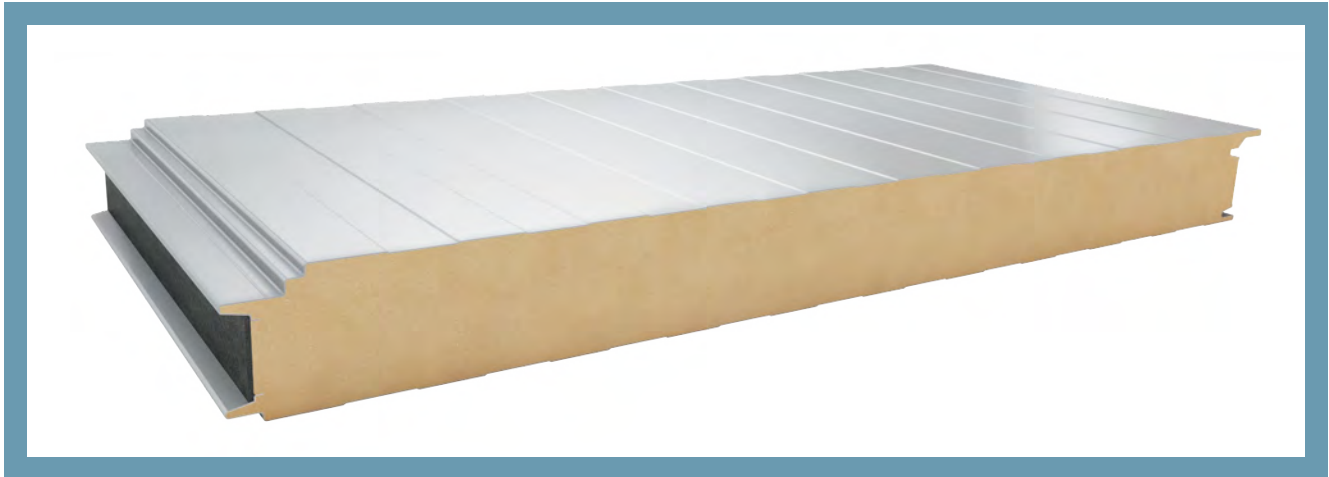

Panels connection scheme

APPLICATION

Wall sandwich panel with visible joint PWPIR-SU is used to construct external walls and internal partitions in the single- or multiple-span shell structure.

The link is hidden in a suitably profiled longitudinal edge of the panel, forming a locking mechanism characteristic for this system, creating an aesthetic appearance of the facade. The panels can be installed both vertically and horizontally, however, in the horizontal layout, the system requires additional panel jointing treatment.

AVAILABLE PROFILATION TYPES

EXTERNAL PROFILATION

- L** - LINEAR
- MF** - MICROWAVE
- ML** - MICROLINEAR
- G** - SMOOTH
- MR** - MICROGROOVE
- C** - CARBON

INTERNAL PROFILATION

- L** - LINEAR
- R** - GROOVE
- G** - SMOOTH

TABLE OF TECHNICAL PARAMETERS OF THE PWPIR-SU PANELS

Parameter	Value			
thickness [mm]	60	80	100	120
modular width [mm]	1050 (optionally 1000) ¹⁾			
length ²⁾ [mm]	2000 ÷ 15800			
weight ³⁾ [kg/m ²]	11,10	11,80	12,60	13,40
heat transfer coefficient U_c [W/m ² K]	0,42	0,29	0,23	0,19
acoustic insulation R_w [dB]	26			
reaction to fire	B-s1, d0			
resistance to external fire ⁴⁾	NRO			
wall fire rating ⁵⁾	NPD		EI 15 (o ← i) ⁵⁾	
anti-corrosive protection	depending on the coating used ⁶⁾			
organic coatings	SP25, PU, AGRO, FOOD SAFE and other ⁶⁾			
external facing	galvanized steel 0,5 ÷ 0,6 mm ⁷⁾			
internal facing	galvanized steel 0,4 ÷ 0,6 mm ⁷⁾			
available profilation types	external facing L, ML, MF, MR ⁸⁾ , G ⁹⁾ , C; internal facing L, R ⁹⁾ , G ⁹⁾			
insulating core	rigid foam of 40 kg/m ³ in total density and with enclosed PIR (polyisocyanurate) cells			
application	non-continuous application on external walls and as wall cladding, on the structural parts of walls and ceilings			
wall application layout	vertical or horizontal			

¹⁾ Minimum production for a modular width of 1000 mm depending on panel thickness is 1000 m².

²⁾ length depends on the color of the external facing and the thickness of the panel

³⁾ average weight of a sandwich panel with 0.5 mm outer facing, including product tolerance

⁴⁾ fire rating concerning the propagation of fire by the wall when the fire acts towards the outside. This property applies to the Polish territory only and is not CE-marked.

⁵⁾ detailed information (including panel layout and support spans) can be found in the General Terms and Conditions of Sale available at paneltech.pl.

⁶⁾ organic coat selected on the basis of durability and application conditions. Coat selection is carried out through environmental assessment and basing on an environmental questionnaire completed by the Client, approved by the steel manufacturer and Paneltech

⁷⁾ other steel types are selected according to application conditions and approved by Paneltech

⁸⁾ detailed information on the MR – microgroove profilation will be provided at individual request

⁹⁾ facings with the G – smooth or R – groove profiles can include microwaves, which affect the appearance of the product classified as compliant with the requirements of EN 14509, annex D

MORE ABOUT PWPIR-SU



CONTACT OUR REPRESENTATIVE



PWPIR-CH

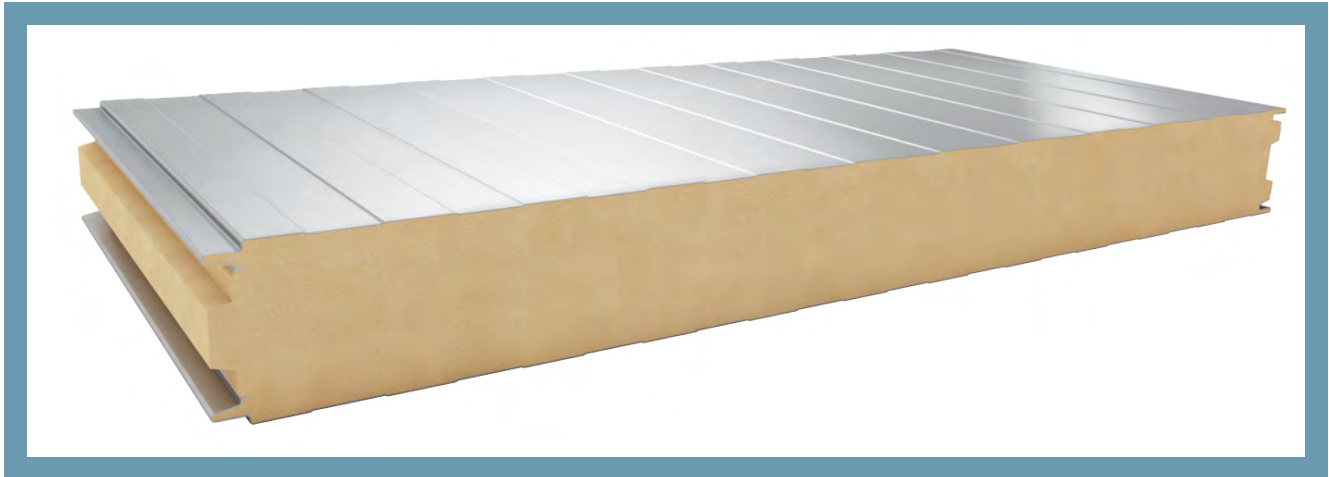

Panels connection scheme

APPLICATION

Coolroom PWPIR-CH sandwich panel is intended for warehouse structures where internal temperatures reach -25°C .

The panel can be installed both vertically and horizontally. Panel edges are custom-cut, and thus provide a very low coefficient of linear distribution of thermal conductivity of the joint, and thus guarantee complete water-tightness and vapor-tightness.

AVAILABLE PROFILATION TYPES

EXTERNAL PROFILATION

- L** - LINEAR
- MF** - MICROWAVE
- ML** - MICROLINEAR
- G** - SMOOTH
- MR** - MICROGROOVE
- C** - CARBON

INTERNAL PROFILATION

- L** - LINEAR
- R** - GROOVE
- G** - SMOOTH

TABLE OF TECHNICAL PARAMETERS OF THE PWPIR-CH PANELS

Parameter	Value			
thickness [mm]	120	160	180	200
modular width [mm]	1130, 1000 (optionally 1050) ¹⁾			
length ²⁾ [mm]	2000 ÷ 15800			
weight ³⁾ [kg/m ²]	13,1	14,7	15,5	16,3
heat transfer coefficient U _c [W/m ² K]	0,18	0,14	0,12	0,11
acoustic insulation Rw [dB]	26			
reaction to fire	B-s1,d0			
resistance to external fire ⁴⁾	NRO			
wall fire rating ⁵⁾	EI 30 (o ↔ i) ⁵⁾			
anti-corrosive protection	depending on the coating used ⁶⁾			
organic coatings	SP25, PU, AGRO, FOOD SAFE and other ⁶⁾			
external facing	galvanized steel 0,5 ÷ 0,6 mm ⁷⁾			
internal facing	galvanized steel 0,4 ÷ 0,6 mm ⁷⁾			
available profilation types	external facing L, ML, MF, MR ⁸⁾ , G ⁹⁾ , C; internal facing L, R ⁹⁾ , G ⁹⁾			
insulating core	rigid foam of 40 kg/m ³ in total density and with enclosed PIR (polyisocyanurate) cells			
application	non-continuous application on external walls and as wall cladding, on the structural parts of walls and ceilings			
wall application layout	vertical or horizontal			

¹⁾ In order to verify the feasibility of a given order, please contact our Customer Service Department or Sales Representative.

²⁾ length depends on the color of the external facing and the thickness of the panel

³⁾ average weight of a sandwich panel with 0.5 mm outer facing, including product tolerance

⁴⁾ fire rating concerning the propagation of fire by the wall when the fire acts towards the outside. This property applies to the Polish territory only and is not CE-marked.

⁵⁾ detailed information (including panel layout and support spans) can be found in the General Terms and Conditions of Sale available at paneltech.pl.

⁶⁾ organic coat selected on the basis of durability and application conditions. Coat selection is carried out through environmental assessment and basing on an environmental questionnaire completed by the Client, approved by the steel manufacturer and Paneltech

⁷⁾ other steel types are selected according to application conditions and approved by Paneltech

⁸⁾ detailed information on the MR – microgroove profilation will be provided at individual request

⁹⁾ facings with the G – smooth or R – groove profiles can include microwaves, which affect the appearance of the product classified as compliant with the requirements of EN 14509, annex D

MORE ABOUT PWPIR-CH



CONTACT OUR REPRESENTATIVE



PWPIR-D

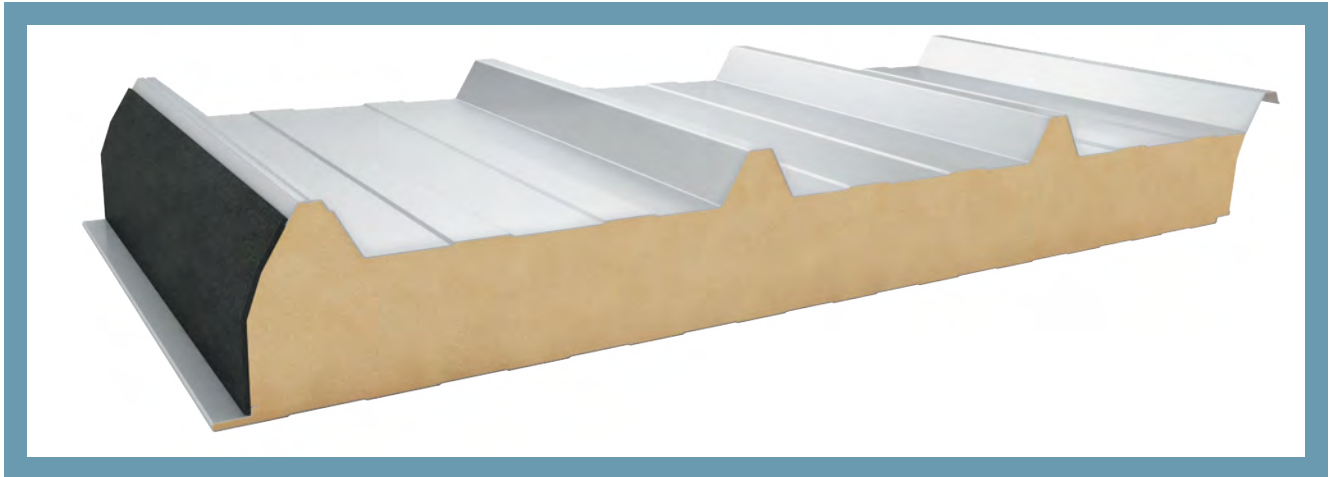

Panels connection scheme

APPLICATION

PWPIR-D roof sandwich panel with a polyisocyanurate (PIR) core is designed for roof coverings. It is characterized by high thermal insulation performance, durability, and enhanced fire resistance properties.

The panel can be used on roofs with a minimum slope of 2.86° (5%) for a continuous covering from the eaves to the ridge, and 5.14° (9%) when panels are joined along their length. Installation is carried out using steel screws, which are fixed through the panel to the building's structure. The PWPIR-D panel is fully compatible with the PWPIR-D LITE roofing panels and is externally compatible with Paneltech roofing panels PWW-D and PWS-D.

The thermal insulation core of the panel is made of rigid polyisocyanurate (PIR) foam with a density of 40 kg/m^3 . The panel facings consist of profiled, galvanized steel sheets coated with protective paint layers. Along the entire length of the core, a factory-installed polyurethane gasket and aluminum tape ensure optimal sealing.

AVAILABLE PROFILATION TYPES

EXTERNAL PROFILATION

T - TRAPEZOIDAL

INTERNAL PROFILATION

L - LINEAR

R - GROOVE

G - SMOOTH

TABLE OF TECHNICAL PARAMETERS OF THE PWPIR-D PANELS

Parameter	Value						
thickness [mm]	40	60	80	100	120	145	160
modular width [mm]	1050						
length ¹⁾ [mm]	2000 ÷ 16000						
weight ²⁾ [kg/m ²]	10,2	11,0	11,8	12,6	13,4	14,5	15,0
heat transfer coefficient U_c [W/m ² K]	0,49	0,34	0,26	0,21	0,18	0,15	0,14
acoustic insulation R_w [dB]	26						
reaction to fire	B-s1, d0						
resistance to external fire	$B_{roof}(t_1)$ and $B_{roof}(t_2)$ and $B_{roof}(t_3)$						
roof fire rating ³⁾	NPD			REI 30 ³⁾			
anti-corrosive protection	depending on the coating used ⁴⁾						
organic coatings	SP25, PU, AGRO, FOOD SAFE and other ⁴⁾						
external facing	galvanized steel 0,5 ÷ 0,6 mm ⁵⁾						
internal facing	galvanized steel 0,4 ÷ 0,6 mm ⁵⁾						
available profilation types	external facing T; internal facing L, R ⁶⁾ , G ⁶⁾						
insulating core	rigid foam of 40 kg/m ³ in total density and with enclosed cells						
application	non-continuous application on roofs and roof covers						

¹⁾ length depends on the color of the external facing and the thickness of the panel

²⁾ average weight of a sandwich panel with 0.5 mm outer facing, including product tolerance

³⁾ detailed information (including panel layout and support spans) can be found in the General Terms and Conditions of Sale available at paneltech.pl.

⁴⁾ organic coat selected on the basis of durability and application conditions. Coat selection is carried out through environmental assessment and basing on an environmental questionnaire completed by the Client, approved by the steel manufacturer and Paneltech

⁵⁾ other steel types are selected according to application conditions and approved by Paneltech

⁶⁾ facings with the G – smooth or R – groove profiles can include microwaves, which affect the appearance of the product classified as compliant with the requirements of EN 14509, annex D

MORE ABOUT PWPIR-D



CONTACT OUR REPRESENTATIVE



PWPIR-D LITE

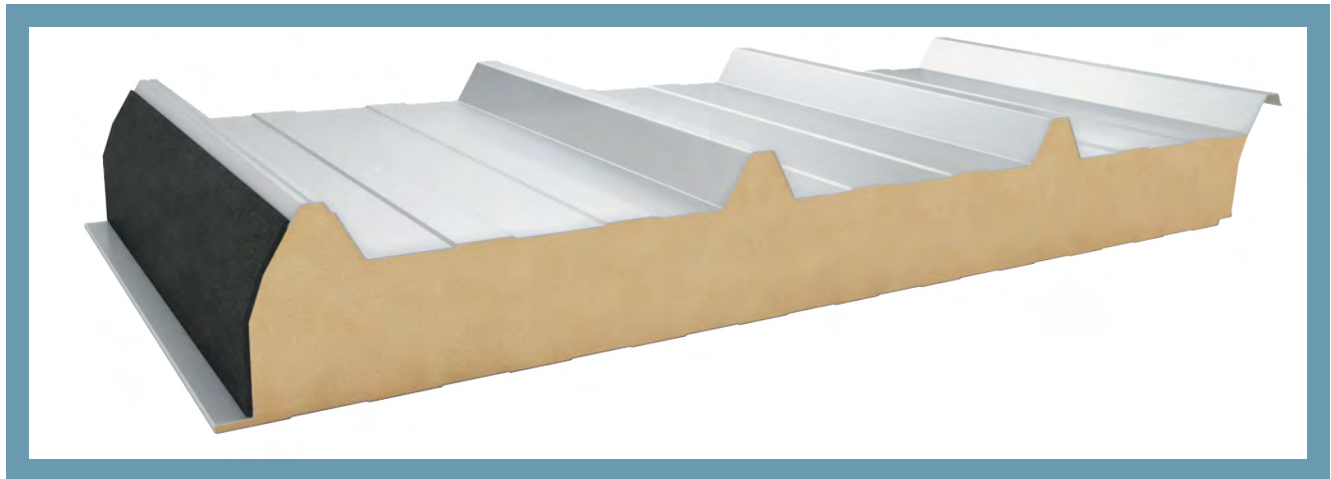

Panels connection scheme

APPLICATION

PWPIR-D LITE roof sandwich panel is designed for roofs and roof coverings. It is characterised by its favourable price, excellent thermal insulation and durability.

The panel can be used on roofs with a minimum slope of 2.86° (5%) for a continuous covering from the eaves to the ridge, and 5.14° (9%) when panels are joined along their length. Installation is carried out using steel screws, which are fixed through the panel to the building's structure. PWPIR-D LITE is fully compatible with PWPIR-D roof panels and externally compatible with Paneltech PWW-D and PWS-D roof panels.

The thermal insulation core of the board is a rigid polyisocyanurate (PIR) foam with a density of 35 kg/m³, providing very good insulation properties. Despite the lower density, the board has good thermal insulation properties and strength. **However, there is a possibility of micro irregularities on its surface. Therefore PWPIR-D LITE is not recommended for applications where high aesthetics are required.**

AVAILABLE PROFILATION TYPES

EXTERNAL PROFILATION

T - TRAPEZOIDAL

INTERNAL PROFILATION

L - LINEAR

TABLE OF TECHNICAL PARAMETERS OF THE PWPIR-D LITE PANELS

Parameter	Value				
thickness [mm]	80	100	120	145	160
modular width [mm]	1050				
length ¹⁾ [mm]	2000 ÷ 16000				
weight ²⁾ [kg/m ²]	11,3	12,0	12,7	13,3	14,0
heat transfer coefficient U_c [W/m ² K]	0,27	0,22	0,18	0,16	0,14
acoustic insulation R_w [dB]	NPD				
reaction to fire	B-s1,d0				
resistance to external fire	$B_{roof}(t_1)$ and $B_{roof}(t_2)$ and $B_{roof}(t_3)$				
wall fire rating ³⁾	NPD	REI 15 ³⁾			
anti-corrosive protection	depending on the coating used ⁴⁾				
organic coatings	SP25				
external facing	galvanized steel 0,5 mm ⁵⁾				
internal facing	galvanized steel 0,4 ÷ 0,5 mm ⁵⁾				
available profilation types	external facing T; internal facing L				
insulating core	rigid foam of 35 kg/m ³ in total density and with enclosed PIR (polyisocyanurate) cells				
application	non-continuous application on roofs and roof covers				

¹⁾ length depends on the color of the external facing and the thickness of the panel

²⁾ average weight of a sandwich panel with 0.5 mm outer facing, including product tolerance

³⁾ detailed information (including panel layout and support spans) can be found in the General Terms and Conditions of Sale available at paneltech.pl.

⁴⁾ organic coat selected on the basis of durability and application conditions. Coat selection is carried out through environmental assessment and basing on an environmental questionnaire completed by the Client, approved by the steel manufacturer and Paneltech

⁵⁾ other steel types are selected according to application conditions and approved by Paneltech

MORE ABOUT PWPIR-D LITE



CONTACT OUR REPRESENTATIVE



PWW-S



Panels connection scheme

APPLICATION

PWW-S wall sandwich panel with a visible joint and a mineral wool core is designed for the installation of external and internal partition walls, as well as suspended ceilings. This panel stands out due to its excellent fire resistance, good thermal insulation properties, and high durability.

The installation of the panel can be carried out both vertically and horizontally, using steel screws that pass through the panel into the building structure. The panel is fully compatible with the PWS-S and PWW-S LITE wall panels and is externally and internally compatible with the Paneltech PWPIR-S, PWPIR-S LITE, and PWPIR-CH wall panels.

The insulating core of the panel is made of mineral wool with a density of 100 kg/m³, while the facings consist of profiled, galvanized steel sheets coated with protective paint layers. The edge joints of the core are designed in such a way that they do not require the use of additional sealing materials.

AVAILABLE PROFILATION TYPES

EXTERNAL PROFILATION

- L** - LINEAR
- MF** - MICROWAVE
- ML** - MICROLINEAR
- G** - SMOOTH

INTERNAL PROFILATION

- L** - LINEAR
- R** - GROOVE
- G** - SMOOTH

TABLE OF TECHNICAL PARAMETERS OF THE PWW-S PANELS

Parameter	Value								
thickness [mm]	60	80	100	120	140	150	160	180	200
modular width [mm]	1130, 1000 (optionally 1050) ¹⁾								
length ²⁾ [mm]	2000 ÷ 10000								
weight ³⁾ for PWW-S [kg/m ²]	14,1	16,1	18,1	20,1	22,1	23,1	24,1	26,1	28,1
heat transfer coefficient U _c for PWW-S [W/m ² K]	0,66	0,49	0,39	0,33	0,28	0,27	0,25	0,22	0,20
acoustic insulation Rw [dB]	31		33	31				34	
reaction to fire	A2-s1,d0								
resistance to external fire ⁴⁾	NRO								
wall fire rating ⁵⁾	NPD	EI 30 (o ↔ i) ⁵⁾	EI 90 (o ↔ i) ⁵⁾	EI 120 / EI 180 (o ↔ i) ⁵⁾				EI 180 / EI 240 (o ↔ i) ⁵⁾	
anti-corrosive protection	depending on the coating used ⁶⁾								
organic coatings	SP25, PU, AGRO, FOOD SAFE and other ⁶⁾								
external facing	galvanized steel 0,5 ÷ 0,6 mm ⁷⁾								
internal facing	galvanized steel 0,5 ÷ 0,6 mm ⁷⁾								
available profilation types	external facing L, ML, MF, G ⁸⁾ ; internal facing L, R ⁸⁾ , G ⁸⁾								
insulating core	rock, inflammable mineral wool with a lamella fiber structure 100 kg/m ³								
application	non-continuous application on external walls and as wall cladding, on the structural parts of walls and ceilings								
wall application layout	vertical or horizontal								

¹⁾ In order to verify the feasibility of a given order, please contact our Customer Service Department or Sales Representative.

²⁾ length depends on the color of the external facing and the thickness of the panel

³⁾ average weight of a sandwich panel with 0.5 mm outer facing, including product tolerance

⁴⁾ fire rating concerning the propagation of fire by the wall when the fire acts towards the outside. This property applies to the Polish territory only and is not CE-marked.

⁵⁾ detailed information (including panel layout and support spans) can be found in the General Terms and Conditions of Sale available at paneltech.pl.

⁶⁾ organic coat selected on the basis of durability and application conditions. Coat selection is carried out through environmental assessment and basing on an environmental questionnaire completed by the Client, approved by the steel manufacturer and Paneltech

⁷⁾ other steel types are selected according to application conditions and approved by Paneltech

⁸⁾ facings with the G – smooth or R – groove profiles can include microwaves, which affect the appearance of the product classified as compliant with the requirements of EN 14509, annex D

MORE ABOUT PWW-S



CONTACT OUR REPRESENTATIVE



PWW-S LITE



Panels connection scheme

APPLICATION

PWW-S LITE wall sandwich panel with a mineral wool core and a visible joint has been designed for the construction of external and internal partition walls, as well as suspended ceilings. It is characterized by a competitive price, good fire resistance, and effective thermal insulation properties.

The panel is installed both vertically and horizontally using steel screws that pass through the panel into the structural elements of the building. It is fully compatible with the PWW-S wall panel and is externally and internally compatible with other Paneltech wall panels, such as PWPIR-S and PWPIR-S LITE.

The insulating core of the panel consists of mineral wool with a density of 85 kg/m³. The panel facings are made of profiled, galvanized steel sheets coated with protective paint layers. The edge joints of the core have been designed in such a way that they do not require additional sealing.

AVAILABLE PROFILATION TYPES

EXTERNAL PROFILATION

- L** - LINEAR
- MF** - MICROWAVE
- ML** - MICROLINEAR
- G** - SMOOTH

INTERNAL PROFILATION

- L** - LINEAR
- R** - GROOVE
- G** - SMOOTH

TABLE OF TECHNICAL PARAMETERS OF THE PWW-S LITE PANELS

Parameter	Value						
thickness [mm]	100	120	140	150	160	180	200
modular width [mm]	1130, 1000 (optionally 1050) ¹⁾						
length ²⁾ [mm]	2000 ÷ 10000						
weight ³⁾ [kg/m ²]	16,6	18,3	20	20,9	21,7	23,4	25,1
heat transfer coefficient U _c [W/m ² K]	0,38	0,32	0,27	0,25	0,24	0,21	0,19
acoustic insulation Rw [dB]	33	31					34
reaction to fire	A2-s1,d0						
resistance to external fire ⁴⁾	NRO						
wall fire rating ⁵⁾	EI 90 (o ↔ i) ⁵⁾						
anti-corrosive protection	depending on the coating used ⁶⁾						
organic coatings	SP25, PU, AGRO, FOOD SAFE and other ⁶⁾						
external facing	galvanized steel 0,5 ÷ 0,6 mm ⁷⁾						
internal facing	galvanized steel 0,5 ÷ 0,6 mm ⁷⁾						
available profilation types	external facing L, ML, MF, G ⁸⁾ ; internal facing L, R ⁸⁾ , G ⁸⁾						
insulating core	rock, inflammable mineral wool with a lamella fiber structure 85 kg/m ³						
application	non-continuous application on external walls and as wall cladding, on the structural parts of walls and ceilings						
wall application layout	vertical or horizontal						

¹⁾ In order to verify the feasibility of a given order, please contact our Customer Service Department or Sales Representative.

²⁾ length depends on the color of the external facing and the thickness of the panel

³⁾ average weight of a sandwich panel with 0.5 mm outer facing, including product tolerance

⁴⁾ fire rating concerning the propagation of fire by the wall when the fire acts towards the outside. This property applies to the Polish territory only and is not CE-marked.

⁵⁾ detailed information (including panel layout and support spans) can be found in the General Terms and Conditions of Sale available at paneltech.pl.

⁶⁾ organic coat selected on the basis of durability and application conditions. Coat selection is carried out through environmental assessment and basing on an environmental questionnaire completed by the Client, approved by the steel manufacturer and Paneltech

⁷⁾ other steel types are selected according to application conditions and approved by Paneltech

⁸⁾ facings with the G – smooth or R – groove profiles can include microwaves, which affect the appearance of the product classified as compliant with the requirements of EN 14509, annex D

MORE ABOUT PWW-S LITE



CONTACT OUR REPRESENTATIVE



PWW-SU¹⁾

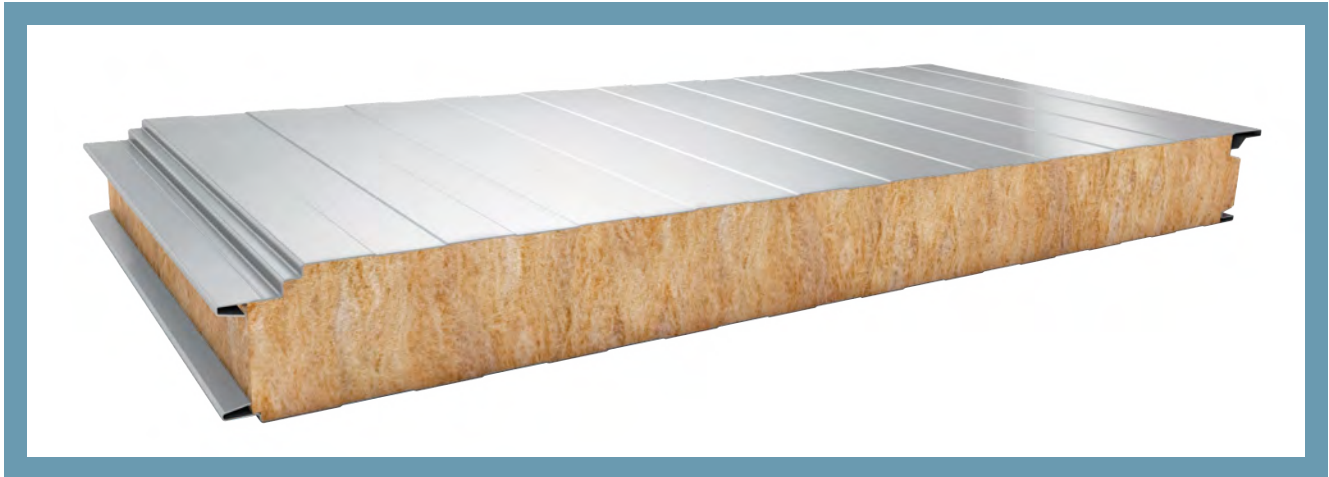

Panels connection scheme

APPLICATION

PWW-SU wall sandwich panel with a hidden joint is used for the construction of external walls (façades), internal partition walls, and suspended ceilings on single- or multi-span skeletal structures.

The joint is hidden within a specially profiled longitudinal edge, forming a lock characteristic of this system, which ensures a clean and aesthetic façade appearance. The installation of the panels can be carried out both vertically and horizontally; however, in the horizontal arrangement, this system requires additional finishing at the panel joints. The panel's core is made of mineral wool with a density of 100 kg/m³. Due to its properties, especially its high fire resistance parameters, this panel can be used in the construction of buildings requiring enhanced fire protection. The PWW-SU panel is externally compatible with the PWPIR-SU wall panel, which has a polyisocyanurate (PIR) core.

AVAILABLE PROFILATION TYPES

EXTERNAL PROFILATION

- L** - LINEAR
- MF** - MICROWAVE
- ML** - MICROLINEAR
- G** - SMOOTH

INTERNAL PROFILATION

- L** - LINEAR
- R** - GROOVE
- G** - SMOOTH

TABLE OF TECHNICAL PARAMETERS OF THE PWW-SU PANELS

Parameter	Value						
thickness [mm]	80	100	120	150	160	180	200
modular width [mm]	1050 (optionally 1000) ¹⁾						
length ²⁾ [mm]	2000 ÷ 10000						
weight ³⁾ for PWW-SU [kg/m ²]	16,4	18,4	20,4	23,4	24,4	26,4	28,4
heat transfer coefficient U _c for PWW-SU [W/m ² K]	0,51	0,41	0,34	0,27	0,25	0,23	0,20
acoustic insulation Rw [dB]	31						
reaction to fire	A2-s1,d0						
resistance to external fire ⁴⁾	NRO						
PWW-SU wall fire rating ⁵⁾	NPD	EI 30 (o ↔ i) ⁵⁾	EI 60 (o ↔ i) ⁵⁾				
anti-corrosive protection	depending on the coating used ⁶⁾						
organic coatings	SP25, PU, AGRO, FOOD SAFE and other ⁶⁾						
external facing	galvanized steel 0,5 ÷ 0,6 mm ⁷⁾						
internal facing	galvanized steel 0,5 ÷ 0,6 mm ⁷⁾						
available profilation types	external facing L, ML, MF, G ⁸⁾ ; internal facing L, R ⁸⁾ , G ⁸⁾						
insulating core	rock, inflammable mineral wool with a lamella fiber structure (100 kg/m ³)						
application	non-continuous application on external walls and as wall cladding, on the structural parts of walls and ceilings						
wall application layout	vertical or horizontal						

¹⁾ Minimum Production Quantity (MPQ) is 1000 m²

²⁾ length depends on the color of the external facing and the thickness of the panel

³⁾ average weight of a sandwich panel with 0.5 mm outer facing, including product tolerance

⁴⁾ fire rating concerning the propagation of fire by the wall when the fire acts towards the outside. This property applies to the Polish territory only and is not CE-marked.

⁵⁾ detailed information (including panel layout and support spans) can be found in the General Terms and Conditions of Sale available at paneltech.pl.

⁶⁾ organic coat selected on the basis of durability and application conditions. Coat selection is carried out through environmental assessment and basing on an environmental questionnaire completed by the Client, approved by the steel manufacturer and Paneltech

⁷⁾ other steel types are selected according to application conditions and approved by Paneltech

⁸⁾ facings with the G – smooth or R – groove profiles can include microwaves, which affect the appearance of the product classified as compliant with the requirements of EN 14509, annex D

MORE ABOUT PWW-SU



CONTACT OUR REPRESENTATIVE



PWW-D¹⁾

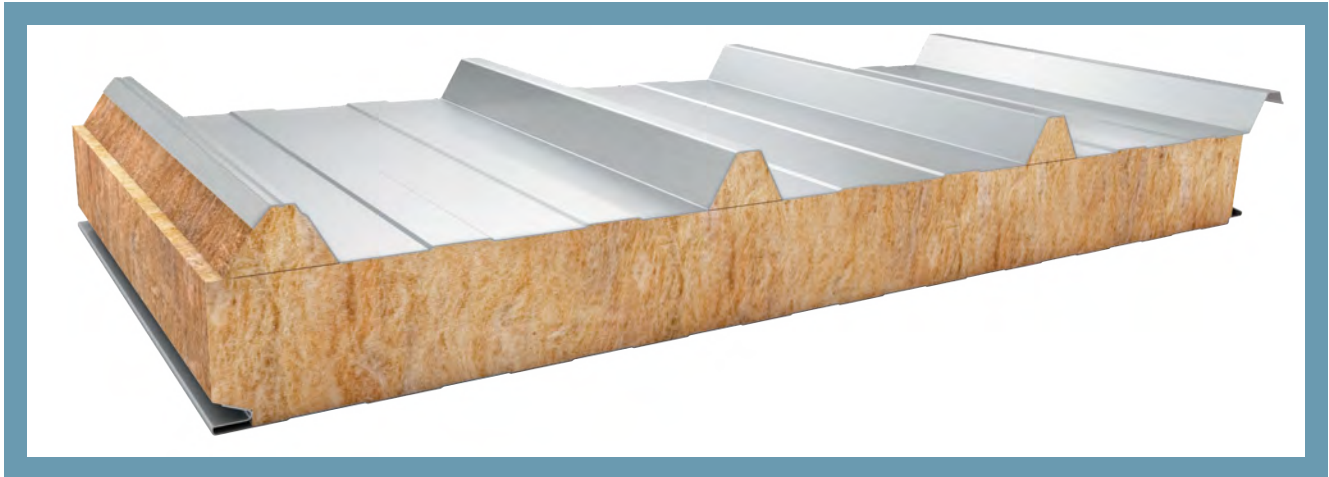

Panels connection scheme

APPLICATION

PWW-D roof sandwich panel with a mineral wool core is designed for roofing and roof coverings in buildings requiring high fire resistance and acoustic insulation. It stands out due to its excellent fire protection properties and good thermal insulation performance.

The panel allows for roof coverings with a minimum slope of 2.86° (5%) when installed as a single element from the eaves to the ridge, and 5.14° (9%) if panels are joined along their length (when the roof length exceeds the recommended production length of the panel). Installation is carried out using steel screws, which are fixed through the panel to the building's structure. The PWW-D panel is fully compatible with PWS-D roofing panels and is externally compatible with Paneltech roofing panels PWPUR-D / PWPIR-D and PWPIR-D LITE.

The insulating core of the panel is made of mineral wool with a density of 100 kg/m³. The panel facings consist of profiled, galvanized steel sheets coated with protective paint layers. The edge joints of the core are designed in such a way that they do not require the use of additional sealing materials.

AVAILABLE PROFILATION TYPES

EXTERNAL PROFILATION

T - TRAPEZOIDAL

INTERNAL PROFILATION

L - LINEAR

R - GROOVE

G - SMOOTH

TABLE OF TECHNICAL PARAMETERS OF THE PWW-D PANELS

Parameter	Value						
thickness [mm]	80	100	120	150	160	180	200
modular width [mm]	1050						
length ²⁾ [mm]	2000 ÷ 10000						
weight ³⁾ [kg/m ²]	16,8	18,8	20,8	23,8	24,8	26,8	28,8
heat transfer coefficient U_c [W/m ² K]	0,46	0,38	0,32	0,26	0,24	0,22	0,20
acoustic insulation R_w [dB]	31						
reaction to fire	A2-s1,d0						
resistance to external fire	B_{roof} ; $B_{roof}(t_1)$ and $B_{roof}(t_2)$ and $B_{roof}(t_3)$						
roof fire rating ⁴⁾	NPD	REI 120 ⁴⁾					
anti-corrosive protection	depending on the coating used ⁵⁾						
organic coatings	SP25, PU, AGRO, FOOD SAFE and other ⁵⁾						
external facing	galvanized steel 0,5 ÷ 0,6 mm ⁶⁾						
internal facing	galvanized steel 0,5 ÷ 0,6 mm ⁶⁾						
available profilation types	external facing T; internal facing L, R ⁷⁾ , G ⁷⁾						
insulating core	rock, inflammable mineral wool with a lamella fiber structure 100 kg/m ³						
application	non-continuous application on roofs and roof covers						

¹⁾ Minimum Production Quantity (MPQ) is from 300m² up to 500m² and depends on thickness of the panel. In order to verify production possibilities of specific order please contact our Customer Service or Sales Representative.

²⁾ length depends on the color of the external facing and the thickness of the panel

³⁾ average weight of a sandwich panel with 0.5 mm outer facing, including product tolerance

⁴⁾ detailed information can be found in the General Terms and Conditions of Sale available at paneltech.pl.

⁵⁾ organic coat selected on the basis of durability and application conditions. Coat selection is carried out through environmental assessment and basing on an environmental questionnaire completed by the Client, approved by the steel manufacturer and Paneltech

⁶⁾ other steel types are selected according to application conditions and approved by Paneltech

⁷⁾ facings with the G – smooth or R – groove profiles can include microwaves, which affect the appearance of the product classified as compliant with the requirements of EN 14509, annex D

MORE ABOUT PWW-D



CONTACT OUR REPRESENTATIVE



PWS-S

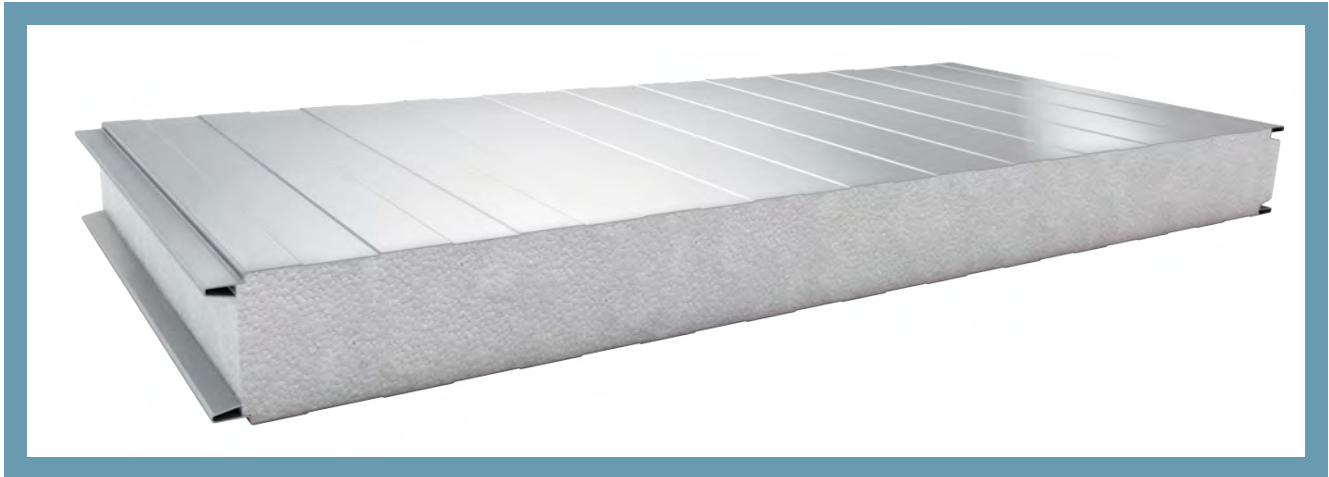

Panels connection scheme

APPLICATION

PWS-S wall sandwich panel with a polystyrene core and a visible joint is designed for the construction of external walls, internal partition walls, and suspended ceilings. This panel is characterized by its lightweight construction, good thermal insulation properties, and attractive price.

The panel can be installed both vertically and horizontally using steel screws, which are fixed through the panel to the building's structure. The PWS-S panel is fully compatible with the PWW-S and PWW-S LITE panels and is externally and internally compatible with other Paneltech wall panels, such as PWPIR-S and PWPIR-S LITE

The thermal insulation core of the panel consists of in-house produced polystyrene with a density of 12.5 kg/m³. The panel facings are made of profiled, galvanized steel sheets coated with protective paint layers, ensuring durability and an aesthetically pleasing façade. The edge joints of the core have been designed in such a way that they do not require the use of additional sealing materials.

AVAILABLE PROFILATION TYPES

EXTERNAL PROFILATION

- L** - LINEAR
- MF** - MICROWAVE
- ML** - MICROLINEAR
- G** - SMOOTH

INTERNAL PROFILATION

- L** - LINEAR
- R** - GROOVE
- G** - SMOOTH

TABLE OF TECHNICAL PARAMETERS OF THE PWS-S PANELS

Parameter	Value					
thickness [mm]	50	80	100	120	150	200
modular width [mm]	1130 (optionally 1000) ¹⁾					
length ²⁾ [mm]	2000 ÷ 10000					
weight ³⁾ [kg/m ²]	8,8	9,1	9,4	9,6	10,0	10,6
heat transfer coefficient U _c [W/m ² K]	0,77	0,48	0,39	0,32	0,26	0,20
resistance to external fire ⁴⁾	NRO					
anti-corrosive protection	depending on the coating used ⁵⁾					
organic coatings	SP25, PU, AGRO, FOOD SAFE and other ⁵⁾					
external facing	galvanized steel 0,5 ÷ 0,6 mm ⁶⁾					
internal facing	galvanized steel 0,4 ÷ 0,5 mm ⁶⁾					
available profilation types	external facing L, ML, MF, G ⁷⁾ ; internal facing L, R ⁷⁾ , G ⁷⁾					
insulating core	expanded polystyrene EPS of 12,5 kg/m ³					
application	non-continuous application on external walls and as wall cladding, on the structural parts of walls and ceilings					
wall application layout	vertical or horizontal					

¹⁾ In order to verify the feasibility of a given order, please contact our Customer Service Department or Sales Representative.

²⁾ length depends on the color of the external facing and the thickness of the panel

³⁾ average weight of a sandwich panel with 0.5 mm outer facing, including product tolerance

⁴⁾ fire rating concerning the propagation of fire by the wall when the fire acts towards the outside. This property applies to the Polish territory only and is not CE-marked.

⁵⁾ organic coat selected on the basis of durability and application conditions. Coat selection is carried out through environmental assessment and basing on an environmental questionnaire completed by the Client, approved by the steel manufacturer and Paneltech

⁶⁾ other steel types are selected according to application conditions and approved by Paneltech

⁷⁾ facings with the G – smooth or R – groove profiles can include microwaves, which affect the appearance of the product classified as compliant with the requirements of EN 14509, annex D

MORE ABOUT PWS-S



CONTACT OUR REPRESENTATIVE



PWS-D¹⁾

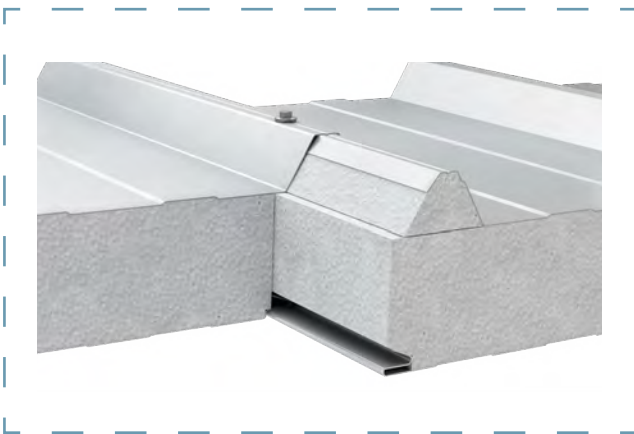
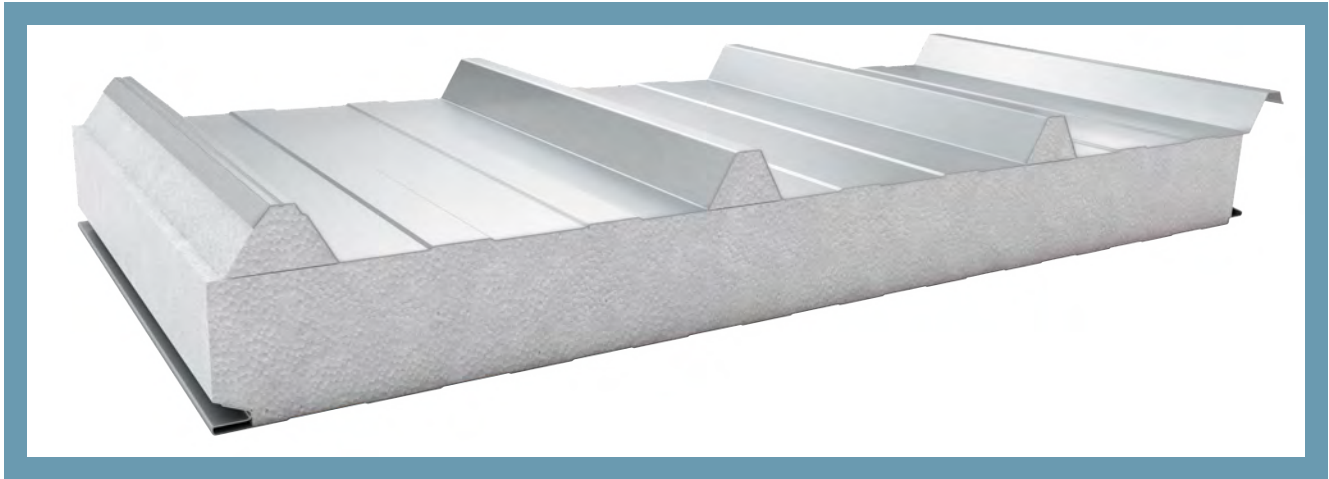

Panels connection scheme

APPLICATION

PWS-D roof sandwich panel with a polystyrene core is designed for roofing and roof coverings on skeletal structures, particularly in buildings where low investment cost is a key criterion.

This panel is characterized by good thermal insulation performance, lightweight construction, and an attractive price. It is fully compatible with PWW-D roofing panels and externally compatible with PWW-D roofing panels with a mineral wool core, as well as PWPIR-D, PWPIR-D LITE, and PWPUR-D roofing panels.

The thermal insulation core of the panel consists of in-house produced polystyrene with a density of 12.5 kg/m³. The external layers are made of galvanized steel sheets coated with organic protective layers, available in various colors and with different properties. The outer side features a distinctive high trapezoidal profiling, ensuring durability and structural integrity.

AVAILABLE PROFILATION TYPES

EXTERNAL PROFILATION

T - TRAPEZOIDAL

INTERNAL PROFILATION

L - LINEAR

R - GROOVE

G - SMOOTH

TABLE OF TECHNICAL PARAMETERS OF THE PWS-D PANELS

Parameter	Value				
thickness [mm]	80	100	120	150	200
modular width [mm]	1050				
length ²⁾ [mm]	2000 ÷ 10000				
weight ³⁾ [kg/m ²]	9,6	9,9	10,2	10,6	11,5
heat transfer coefficient U_c [W/m ² K]	0,45	0,37	0,31	0,25	0,19
resistance to external fire	$B_{roof}(t_1)$				
anti-corrosive protection	depending on the coating used ⁴⁾				
organic coatings	SP25, PU, AGRO, FOOD SAFE and other ⁴⁾				
external facing	galvanized steel 0,5 ÷ 0,6 mm ⁵⁾				
internal facing	galvanized steel 0,4 ÷ 0,5 mm ⁵⁾				
available profilation types	external facing T; internal facing L, R ⁶⁾ , G ⁶⁾				
insulating core	expanded polystyrene EPS of 12,5 kg/m ³				
application	non-continuous application on roofs and roof covers				

¹⁾ Minimum Production Quantity (MPQ) is from 500 m² up to 1000 m² and depends on thickness of the panel. In order to verify production possibilities of specific order please contact our Customer Service or Sales Representative.

²⁾ length depends on the color of the external facing and the thickness of the panel

³⁾ average weight of a sandwich panel with 0.5 mm outer facing, including product tolerance

⁴⁾ organic coat selected on the basis of durability and application conditions. Coat selection is carried out through environmental assessment and basing on an environmental questionnaire completed by the Client, approved by the steel manufacturer and Paneltech

⁵⁾ other steel types are selected according to application conditions and approved by Paneltech

⁶⁾ facings with the G – smooth or R – groove profiles can include microwaves, which affect the appearance of the product classified as compliant with the requirements of EN 14509, annex D

MORE ABOUT PWS-D



CONTACT OUR REPRESENTATIVE







DRAWINGS OF TECHNICAL DETAILS

WALL SANDWICH PANELS

Wall sandwich panel PWPIR-S	57
Wall sandwich panel PWPIR-SU	58
Wall sandwich panel PWS-S / PWW-S	59
Wall sandwich panel PWW-SU.....	60
Joint of externally compatible PWPIR-S and PWW-S / PWS-S wall sandwich panels.....	61
Joint of externally compatible PWPIR-SU and PWW-SU wall sandwich panels.....	62
Drawing 1 - Wall panel and ground beam joint, horizontal and vertical panel layout	63
Drawing 2 - Wall panel and ground beam joint, horizontal and vertical panel layout	63
Drawing 3 - Wall panel and ground beam joint, vertical panel layout	63
Drawing 4 - Wall panel and ground beam joint, horizontal and vertical panel layout	64
Drawing 5 - Wall panel and ground beam joint, horizontal panel layout	64
Drawing 6 - Wall panel and ground beam joint, horizontal panel layout	64
Drawing 7 - Wall panel and ground beam joint, horizontal and vertical panel layout	65
Drawing 8 - Wall panel and column joint - the outermost support, horizontal panel layout	65
Drawing 9 - Corner wall panel joint, horizontal and vertical panel layout	66
Drawing 10 - Corner wall panel joint, horizontal panel layout	66
Drawing 11 - Wall panel and column joint - the outermost support, horizontal panel layout	67
Drawing 12 - Corner wall panel joint, horizontal panel layout	67
Drawing 13 - Wall panel and masonry wall joint, horizontal panel layout	68
Drawing 14 - Expanding wall panel joint, vertical panel layout	68
Drawing 15 - Gate opening - lintel, horizontal and vertical panel layout	69
Drawing 16 - Gate opening - side, horizontal and vertical panel layout	69
Drawing 17 - Gate opening - lintel, horizontal and vertical panel layout	70
Drawing 18 - Gate opening - side, horizontal and vertical panel layout	70
Drawing 19 - Window opening, vertical section, horizontal and vertical panel layout	71
Drawing 20 - Window opening, horizontal section, horizontal and vertical panel layout	71
Drawing 21 - Window opening - vertical section, horizontal and vertical panel layout	72
Drawing 22 - Window opening - horizontal section, horizontal and vertical panel layout	72

COLDROOM SANDWICH PANELS

Coldroom sandwich panel PWPIR-CH.....	75
Joint of externally compatible PWPIR-CH and PWW-S / PWS-S wall sandwich panels.....	76
Drawing 23 - Steel tie for coldroom panels, wall and ceiling	77
Drawing 24 - SWAL LAX tie for coldroom panels, wall and ceiling	77
Drawing 25 - CASTEL COOL screw for coldroom panels, wall and ceiling	77
Drawing 26 - Coldroom external wall panel and floor joint, cold and freezerroom	78
Drawing 27 - Coldroom external wall panel and floor joint, cold and freezerroom	78

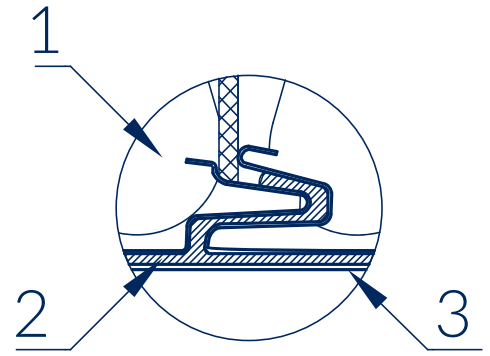

Drawing 28 - Coldroom external wall panel and floor joint, cold and freezerroom	79
Drawing 29 - Coldroom panel and floor joint finish, cold store	79
Drawing 30 - Coldroom panel and floor joint finish	80
Drawing 31 - Coldroom panel and floor joint finish	80
Drawing 32 - Coldroom panel and floor joint finish	80
Drawing 33 - Internal corner finishing	81
Drawing 34 - Internal corner finishing	81
Drawing 35 - Internal corner finishing	81
Drawing 36 - Wall and ceiling joint, cold and freezerroom	82
Drawing 37 - Wall and ceiling joint, cold and freezerroom	82
Drawing 38 - Wall and ceiling joint, cold and freezerroom	82
Drawing 39 - Ceiling suspended on a wall panel, cold and freezerroom	83
Drawing 40 - Ceiling suspended on a panel joint, cold and freezerroom	83
Drawing 41 - Ceiling suspended on a panel joint, cold and freezerroom	83
Drawing 42 - Coldroom door installed in a wall panel, lintel and side	84
Drawing 43 - Coldroom door installed in a wall panel, treshold	84

ROOF SANDWICH PANELS

Roof sandwich panel PWPIR-D	87
Roof sandwich panel PWS-D / PWW-D	88
Joint of externally compatible PWPIR-D and PWW-D / PWS-D roof sandwich panels	89
Drawing 44 - Roof panel joint, ridge	90
Drawing 45 - Roof panel and wall panel joint, guttered eaves	90
Drawing 46 - Roof panel and wall panel joint, guttered eaves	90
Drawing 47 - Roof panel and wall panel joint, guttered eaves	91
Drawing 48 - Roof panel and wall panel joint, guttered eaves	91
Drawing 49 - Expanding roof panel joint, crosswise joint	92
Drawing 50 - Roof panel and wall panel joint, single-sloped roof eaves	92
Drawing 51 - Roof panel and wall panel joint, eaveless single-sloped roof	92
Drawing 52 - Roof panel and wall panel joint, gable eaves	93
Drawing 53 - Roof panel and wall panel joint, eaveless gable	93
Drawing 54 - Roof panel and wall panel joint, single-sloped roof - attic	94
Drawing 55 - Roof panel and wall panel joint, roof side - wall	94
Drawing 56 - Roof panel and wall panel joint, single-sloped roof - masonry wall	95
Drawing 57 - Roof drainage gutter	95
Drawing 58 - Roof panel and skylight joint	96
Drawing 59 - Roof panel and skylight joint	96

WALL SANDWICH PANELS

WALL SANDWICH PANEL
PWPIR-S

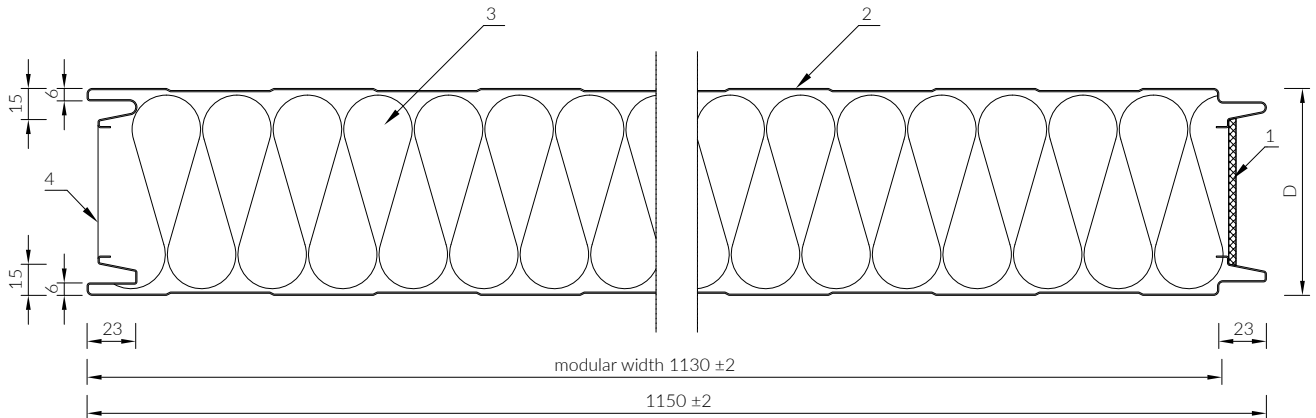

- 1 Polyurethane sealant
- 2 Steel facing
- 3 PIR core
- 4 The arrowhead on the foil points to the external side of the panel

D - panel thickness

The standard modular width of 1130 mm can be optionally changed to 1000 or 1050 mm.
The self-adhesive sealant should be used as required.

WALL PANEL INSTALLATION

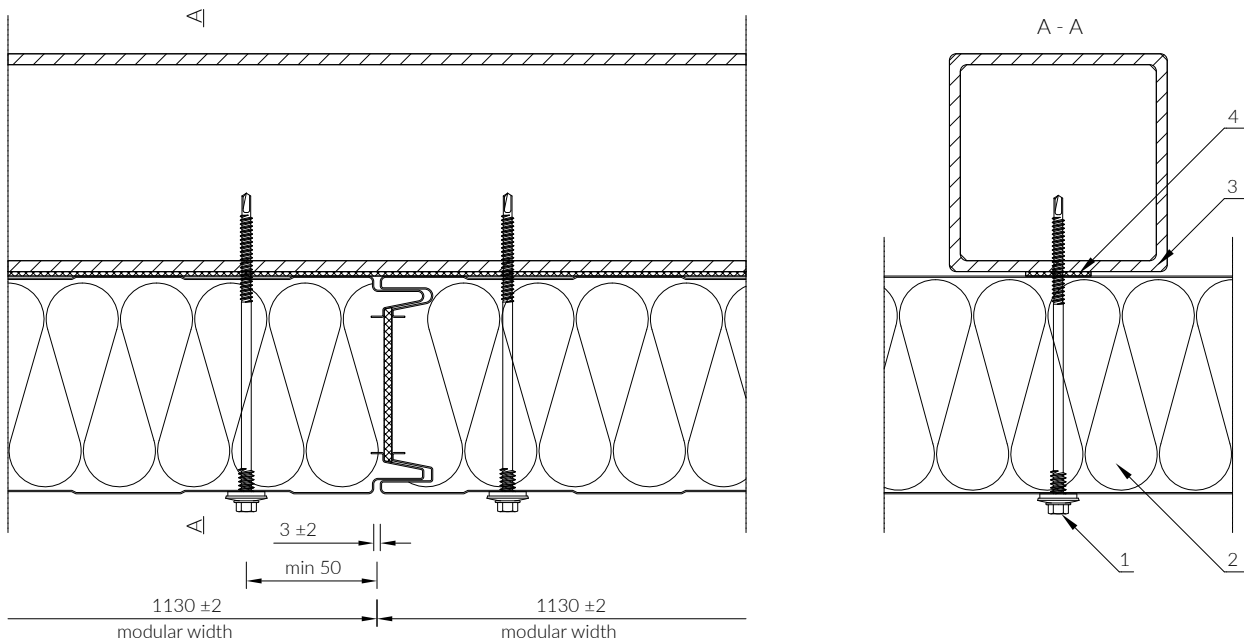

- 1 Fastener
- 2 PaNELTECH wall sandwich panel
- 3 Construction in accordance with building design
- 4 Self adhesive sealant

Select the fastener according to the type and thickness of the construction (steel, wood, reinforced concrete, etc.) and the function of the partition. The number of fasteners is specified in the characteristic loading tables. The self-adhesive sealant should be used as required.

WALL SANDWICH PANEL
PWPIR-SU

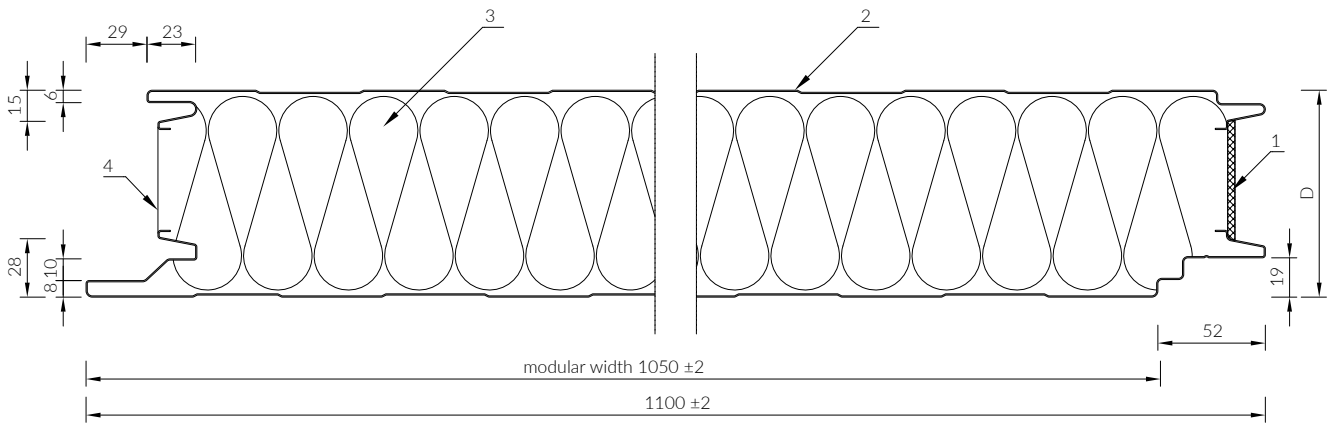

- 1 Polyurethane sealant
- 2 Steel facing
- 3 PIR core
- 4 Aluminum protective foil

D - panel thickness
The standard modular width of 1050 mm can be optionally changed to 1000 mm.

WALL PANEL INSTALLATION

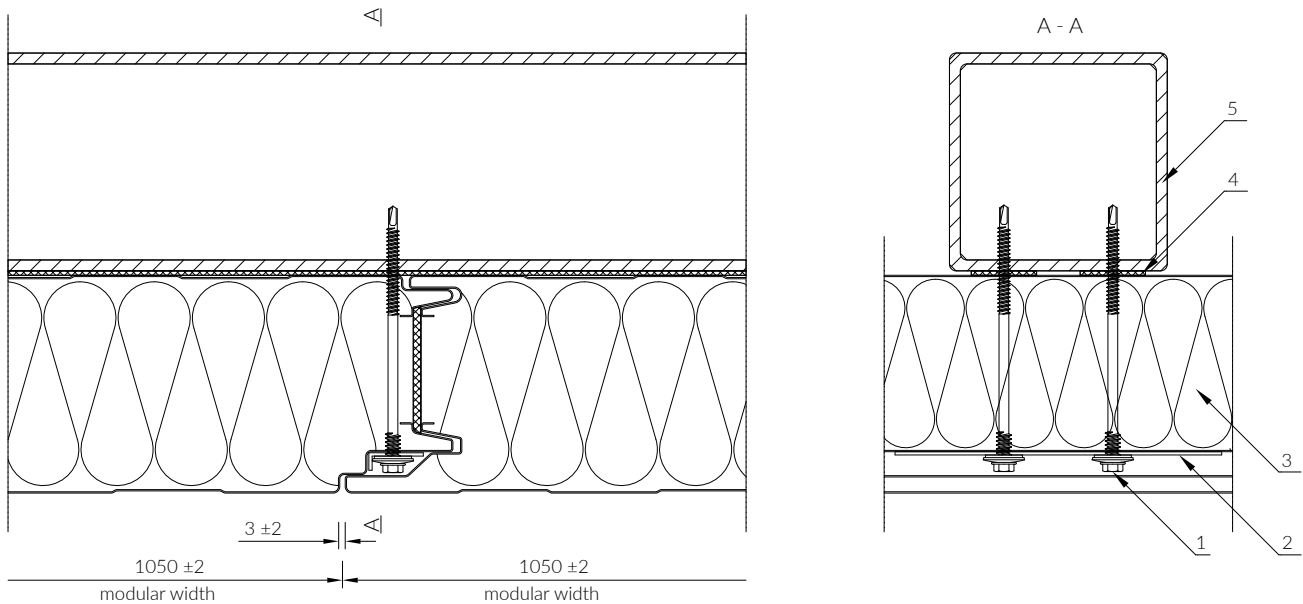

- 1 Fastener
- 2 SU washer
- 3 PaNELTECHwall sandwich panel
- 4 Self adhesive sealant
- 5 Structure as per the construction design

Select the fastener according to the type and thickness of the construction (steel, wood, reinforced concrete, etc.) and the function of the partition. The number of fasteners is specified in the characteristic loading tables. The self-adhesive sealant should be used as required.

WALL SANDWICH PANEL

PWS-S / PWW-S

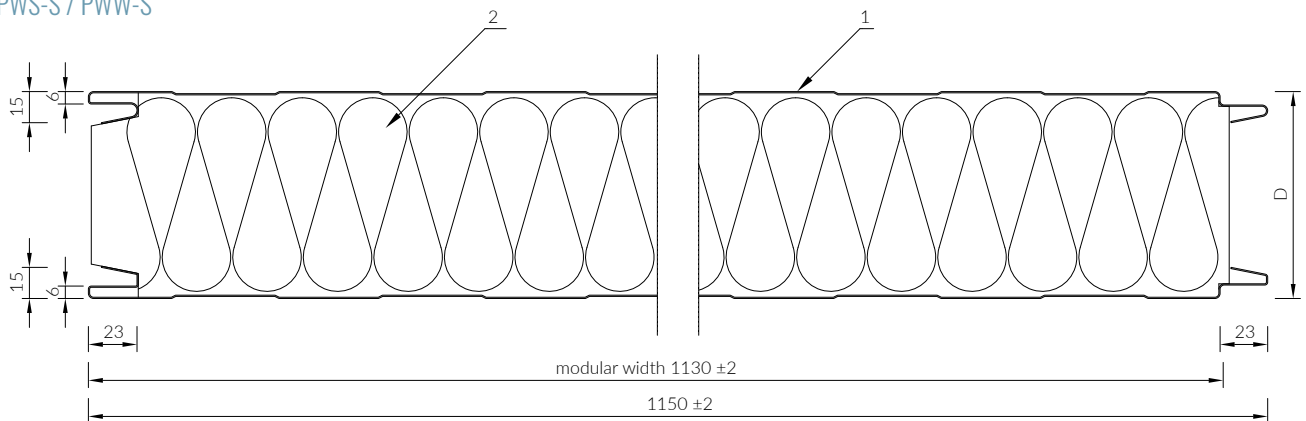

- 1 Steel facing
- 2 EPS or mineral wool core

D - panel thickness

The standard modular width of 1130 mm can be optionally changed to 1000 or 1050 mm.

WALL PANEL INSTALLATION

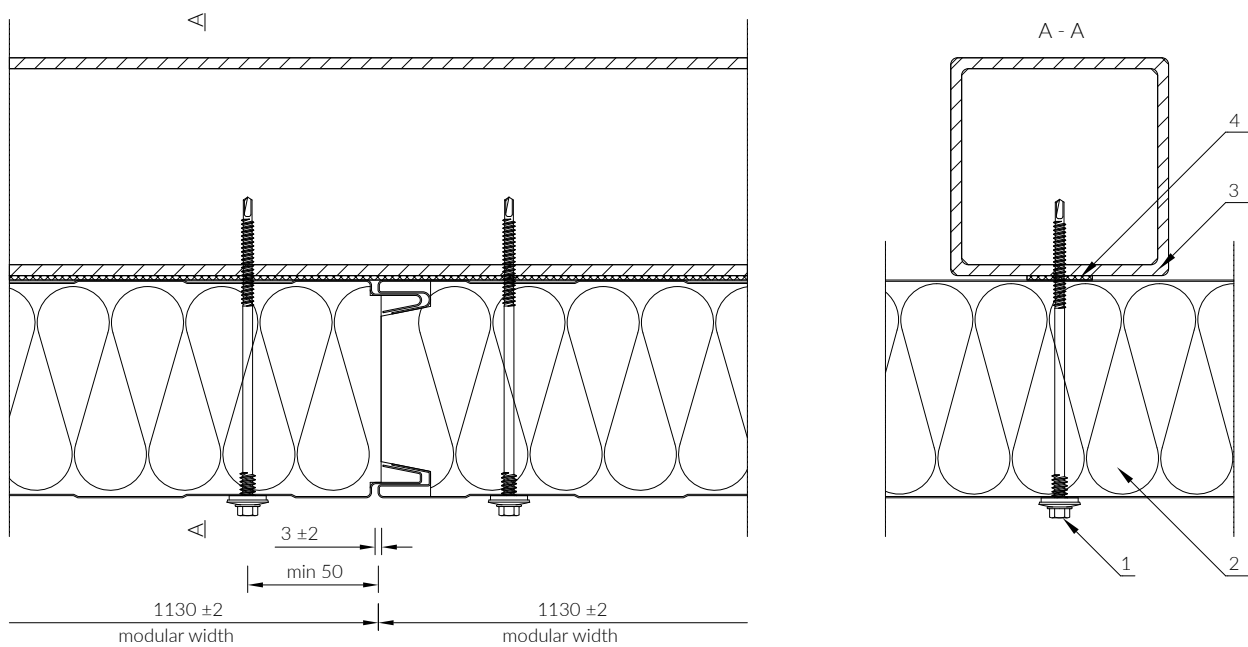

- 1 Fastener
- 2 PaNELTECHwall sandwich panel
- 3 Construction in accordance with building design
- 4 Self adhesive sealant

Select the fastener according to the type and thickness of the construction (steel, wood, reinforced concrete, etc.) and the function of the partition. The number of fasteners is specified in the characteristic loading tables. The self-adhesive sealant should be used as required.

WALL SANDWICH PANEL
PWW-SU

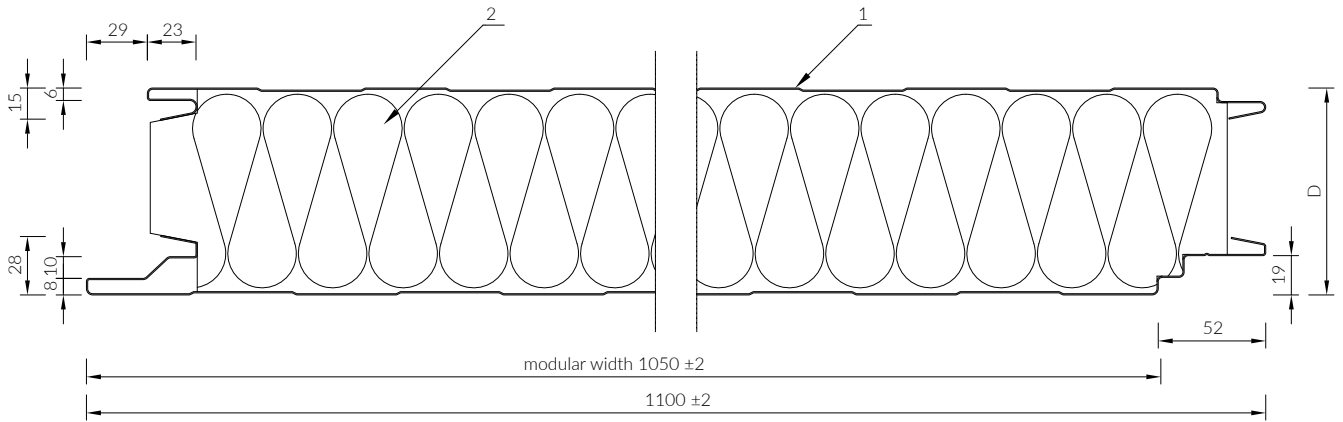

- 1 Steel facing
- 2 Mineral wool core

D - panel thickness

The standard modular width of 1050 mm can be optionally changed to 1000 mm.

WALL PANEL INSTALLATION

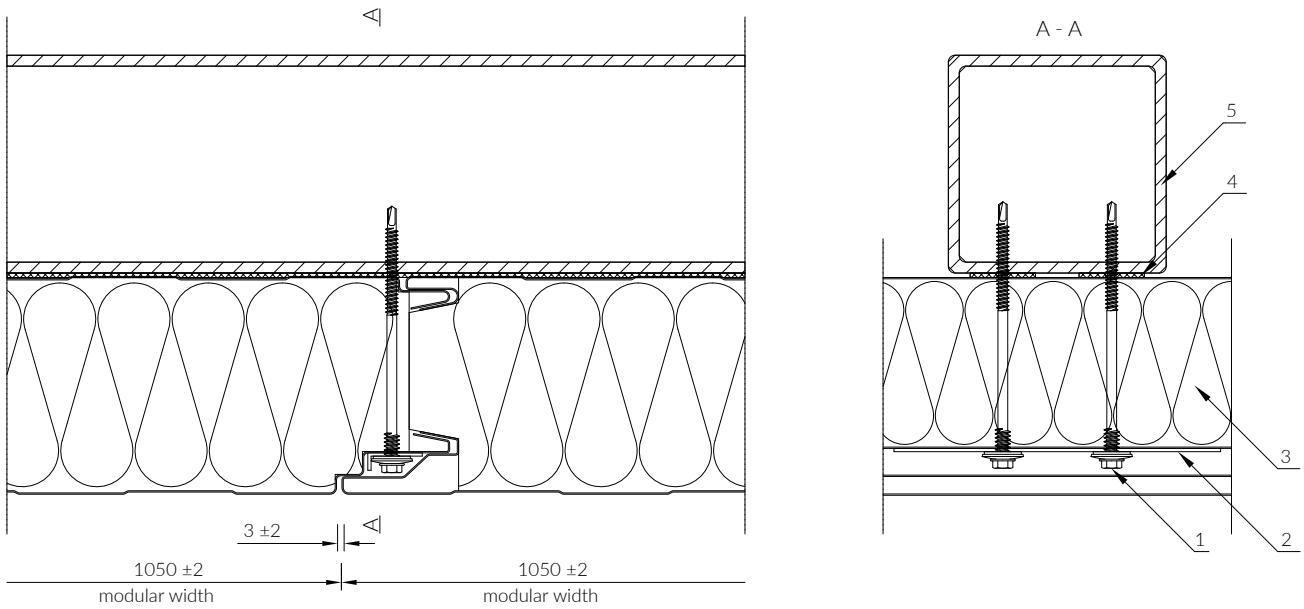

- 1 Fastener
- 2 SU washer
- 3 PaNELTECH wall sandwich panel
- 4 Self adhesive sealant
- 5 Construction in accordance with building design

Select the fastener according to the type and thickness of the construction (steel, wood, reinforced concrete, etc.) and the function of the partition. The number of fasteners is specified in the characteristic loading tables. The self-adhesive sealant should be used as required.

JOINT OF EXTERNALLY COMPATIBLE
PWPIR-S AND PWW-S / PWS-S WALL SANDWICH PANELS

CONFIGURATION 1.
PWPIR-S TONGUE, PWW-S / PWS-S GROOVE

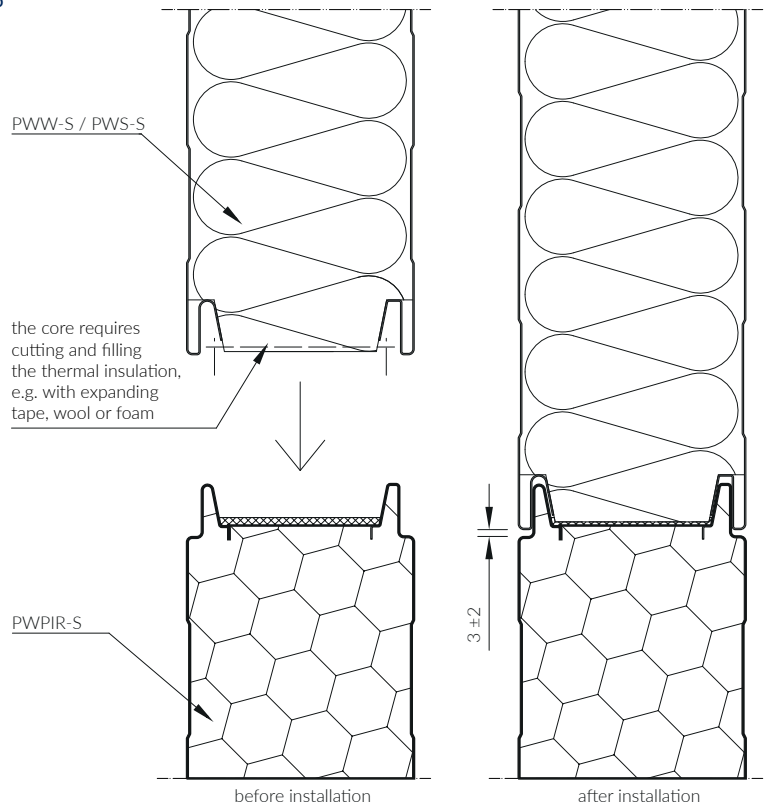

JOINT OF EXTERNALLY COMPATIBLE
PWPIR-S AND PWW-S / PWS-S WALL SANDWICH PANELS

CONFIGURATION 2.
PWW-S / PWS-S TONGUE, PWPIR-S GROOVE

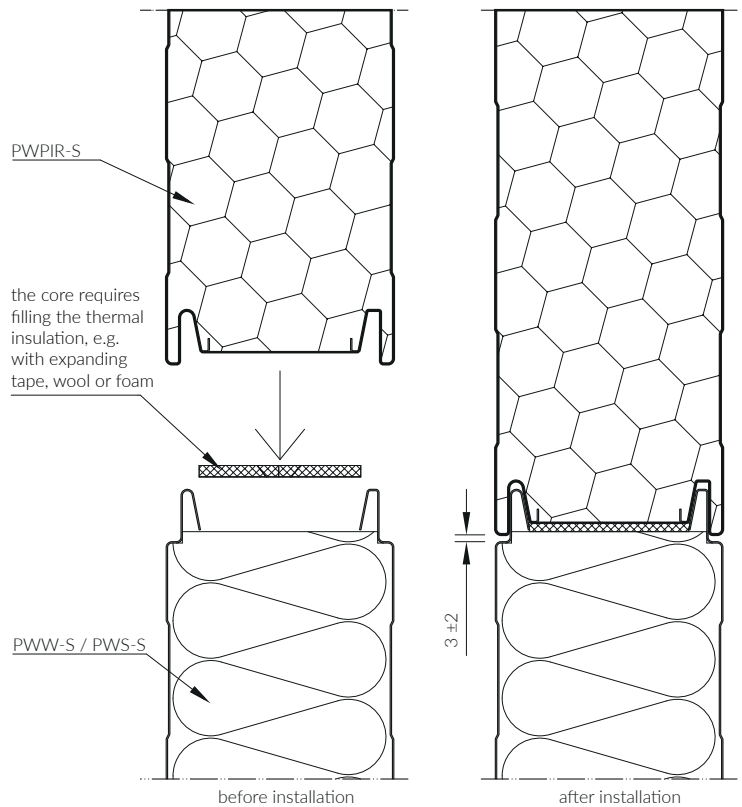

JOINT OF EXTERNALLY COMPATIBLE
PWPIR-SU AND PWW-SU WALL SANDWICH PANELS

CONFIGURATION 1.
PWPIR-SU TONGUE, PWW-SU GROOVE

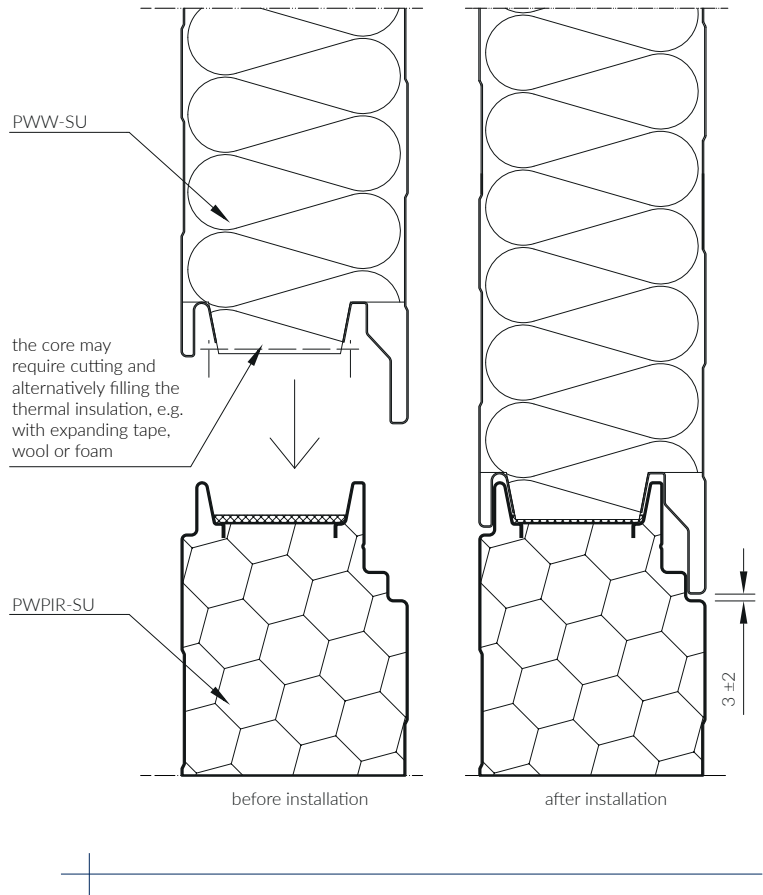

JOINT OF EXTERNALLY COMPATIBLE
PWPIR-SU AND PWW-SU WALL SANDWICH PANELS

CONFIGURATION 2.
PWW-SU TONGUE, PWPIR-SU GROOVE

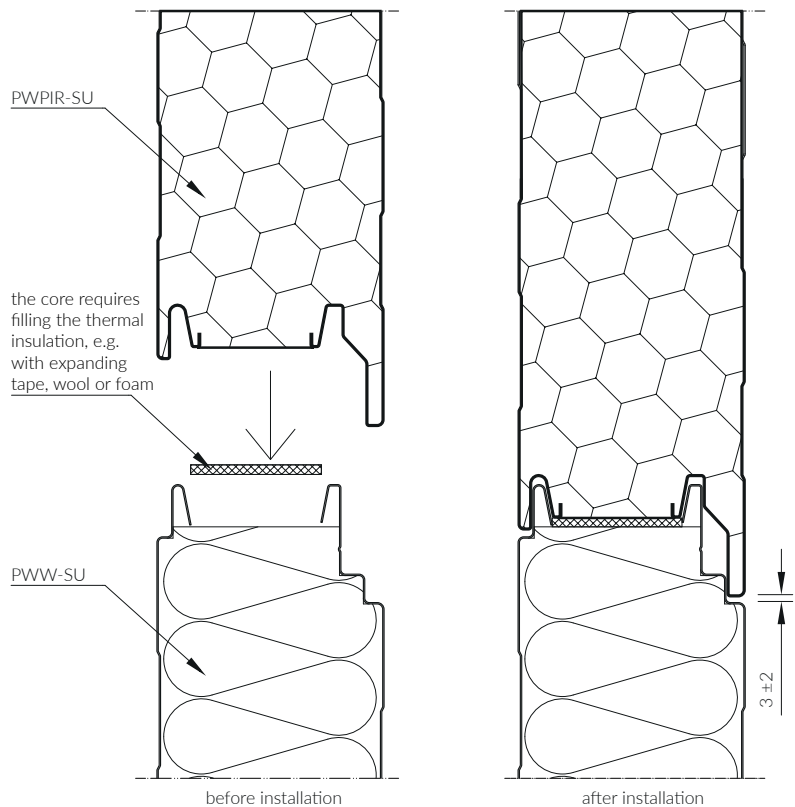

WALL PANEL AND GROUND BEAM JOINT
HORIZONTAL AND VERTICAL PANEL LAYOUT

- 1 Thermal insulation of the ground beam
- 2 005 flashing*
- 3 001 flashing
- 4 Fastener
- 5 Self-drilling screw or blind rivet
- 6 PaNELTECH wall sandwich panel
- 7 010 flashing*
- 8 Self adhesive sealant*
- 9 Construction in accordance with building design
- 10 Sealant or assembly foam
- 11 Ground beam

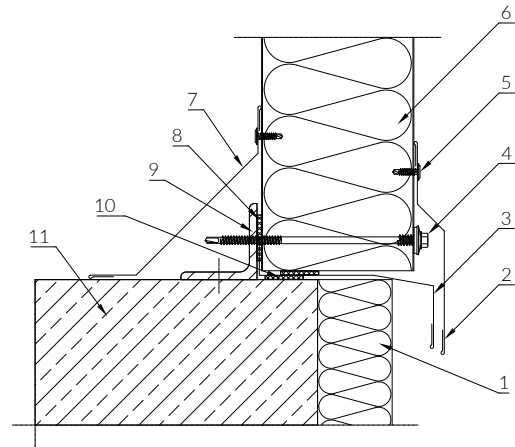

Drawing 1

WALL PANEL AND GROUND BEAM JOINT
HORIZONTAL AND VERTICAL PANEL LAYOUT

- 1 Thermal insulation of the ground beam
- 2 001 flashing*
- 3 020 flashing*
- 4 005 flashing*
- 5 Fastener
- 6 Self-drilling screw or blind rivet
- 7 PaNELTECH wall sandwich panel
- 8 010 flashing*
- 9 Self adhesive sealant*
- 10 Construction in accordance with building design
- 11 Sealant or assembly foam
- 12 Ground beam

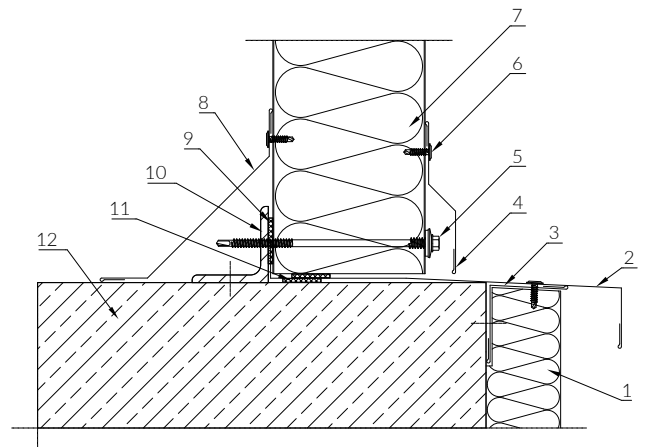

Drawing 2

WALL PANEL AND GROUND BEAM JOINT
VERTICAL PANEL LAYOUT (SOLUTION NOT RECOMMENDED)

- 1 Thermal insulation of the ground beam
- 2 Fastener
- 3 009 flashing
- 4 Sealant or assembly foam
- 5 Self-drilling screw or blind rivet
- 6 Watertight sealing mass
- 7 PaNELTECH wall sandwich panel
- 8 010 flashing*
- 9 Self adhesive sealant*
- 10 Construction in accordance with building design
- 11 Ground beam

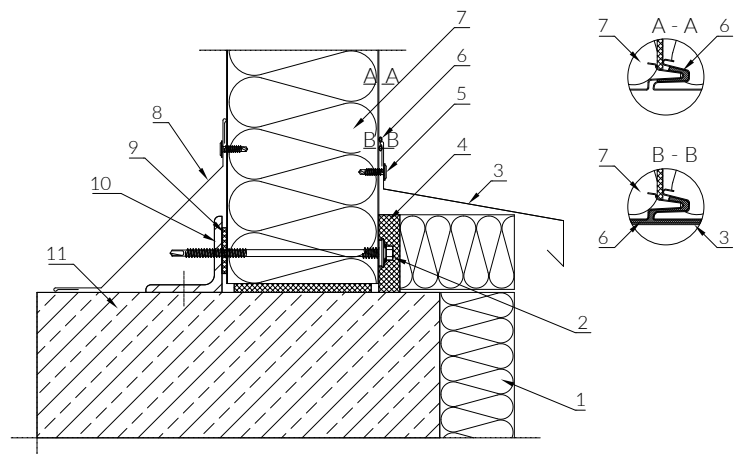

Drawing 3

* as required

WALL PANEL AND GROUND BEAM JOINT
HORIZONTAL AND VERTICAL PANEL LAYOUT

- 1 Thermal insulation of the ground beam
- 2 Construction in accordance with building design or 075 flashing
- 3 005 flashing*
- 4 001 flashing
- 5 Self-drilling screw or blind rivet
- 6 Fastener
- 7 PaNELTECH wall sandwich panel
- 8 010 flashing*
- 9 Self adhesive sealant*
- 10 Construction in accordance with building design
- 11 Facing cutting executed at the construction site*
- 12 Sealant or assembly foam
- 13 Ground beam

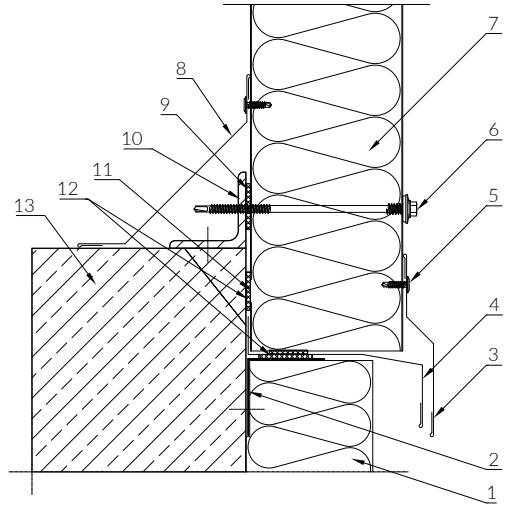

Drawing 4

WALL PANEL AND GROUND BEAM JOINT
HORIZONTAL PANEL LAYOUT (SOLUTION NOT RECOMMENDED)

- 1 Thermal insulation of the ground beam
- 2 Construction in accordance with building design or 076 flashing
- 3 007 flashing*
- 4 003 B flashing*
- 5 Blind rivet
- 6 Self-drilling screw or blind rivet
- 7 Thermal insulation
- 8 PaNELTECH wall sandwich panel
- 9 Self adhesive sealant*
- 10 Construction in accordance with building design
- 11 Ground beam

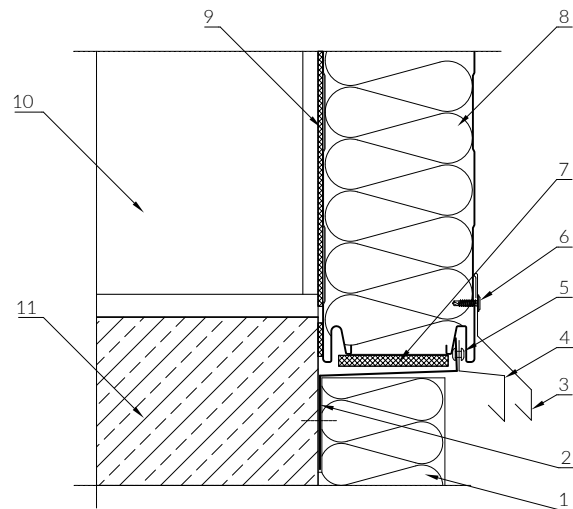

Drawing 5

WALL PANEL AND GROUND BEAM JOINT
HORIZONTAL PANEL LAYOUT (SOLUTION NOT RECOMMENDED)

- 1 Construction in accordance with building design or 075 flashing
- 2 Thermal insulation of the ground beam
- 3 009 flashing
- 4 Thermal insulation
- 5 Self-drilling screw or blind rivet
- 6 Watertight sealing mass
- 7 PaNELTECH wall sandwich panel
- 8 Self adhesive sealant*
- 9 Construction in accordance with building design
- 10 Ground beam

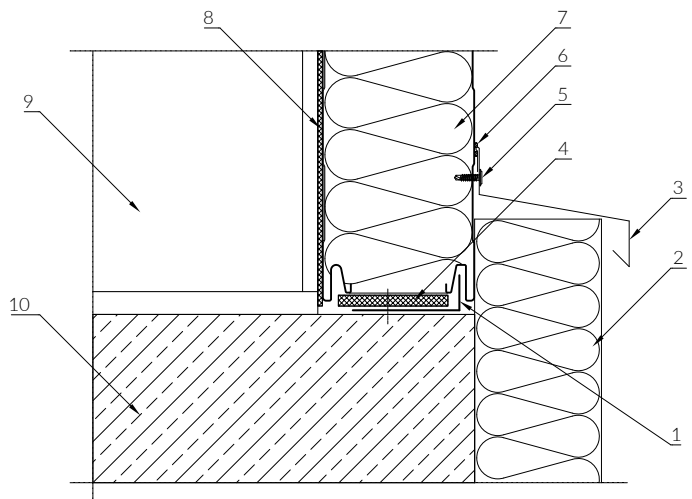

Drawing 6

* as required

WALL PANEL AND GROUND BEAM JOINT
HORIZONTAL AND VERTICAL PANEL LAYOUT

- 1 Thermal insulation of the ground beam
- 2 004 flashing
- 3 006 flashing
- 4 Self-drilling screw or blind rivet
- 5 Fastener
- 6 PaNELTECHwall sandwich panel
- 7 Self adhesive sealant*
- 8 Construction in accordance with building design
- 9 Sealant or assembly foam
- 10 Ground beam

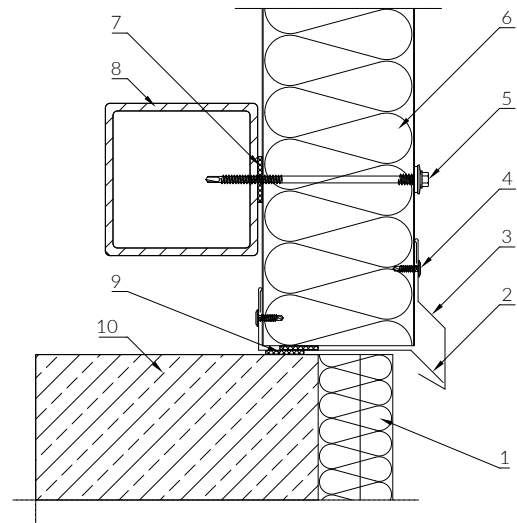

Drawing 7

WALL PANEL AND COLUMN JOINT - THE OUTERMOST SUPPORT
HORIZONTAL PANEL LAYOUT

- 1 Watertight sealing mass*
- 2 Fastener
- 3 028 flashing
- 4 Self-drilling screw or blind rivet
- 5 PaNELTECH wall sandwich panel
- 6 Self adhesive sealant*
- 7 Construction in accordance with building design
- 8 Thermal insulation

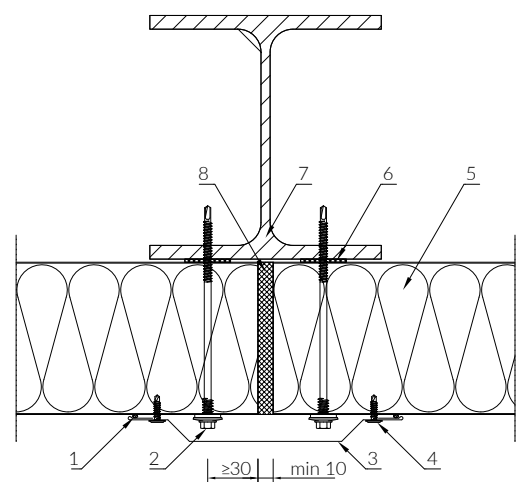

Drawing 8

* as required

CORNER WALL PANEL JOINT

HORIZONTAL AND VERTICAL PANEL LAYOUT

- 1 Watertight sealing mass*
- 2 Thermal insulation
- 3 Facing cutting executed at the construction site*
- 4 O18 flashing
- 5 Fastener
- 6 Self-drilling screw or blind rivet
- 7 PaNELTECH wall sandwich panel
- 8 Construction in accordance with building design
- 9 Self adhesive sealant*

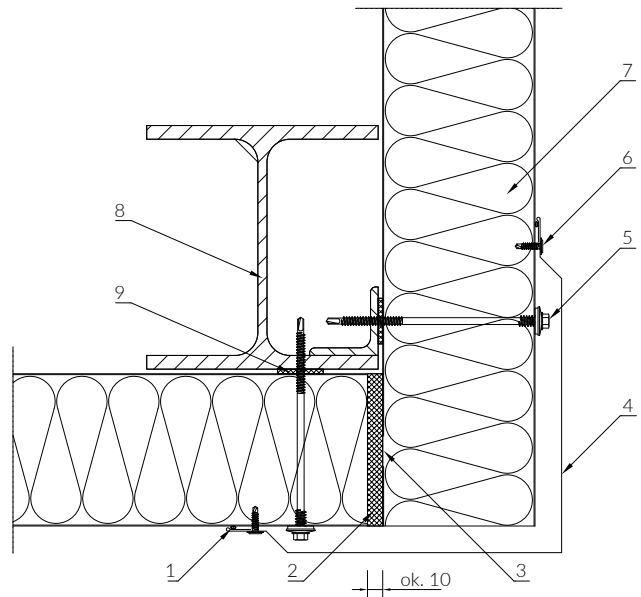

Drawing 9

CORNER WALL PANEL JOINT

HORIZONTAL PANEL LAYOUT

- 1 Fastener
- 2 Watertight sealing mass*
- 3 O15 flashing
- 4 Self-drilling screw or blind rivet
- 5 Thermal insulation
- 6 PaNELTECH wall sandwich panel
- 7 Construction in accordance with building design
- 8 Self adhesive sealant*

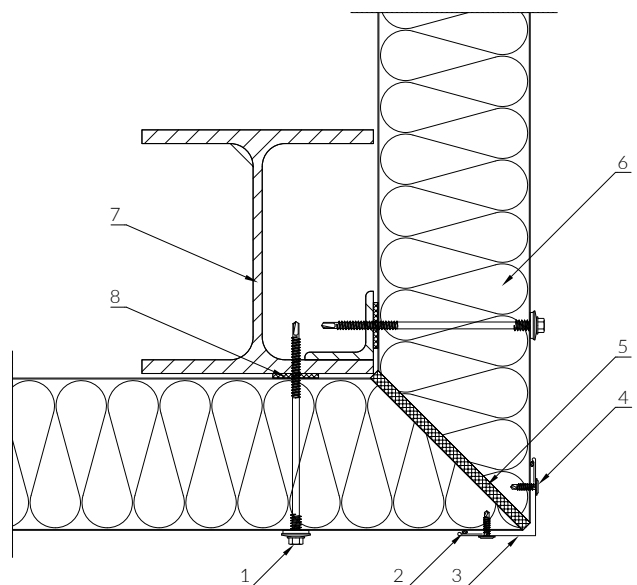

Drawing 10

* as required

WALL PANEL AND COLUMN JOINT - THE OUTERMOST SUPPORT
 HORIZONTAL PANELS WITH HIDDEN JOINTS LAYOUT

- 1 030.3 flashing
- 2 030.2 flashing
- 3 030.1 flashing
- 4 Self-drilling screw or blind rivet
- 5 Watertight sealing mass*
- 6 SU washer
- 7 PaNELTECH SU wall sandwich panel
- 8 Fastener
- 9 Self adhesive sealant*
- 10 Thermal insulation
- 11 Construction in accordance with building design

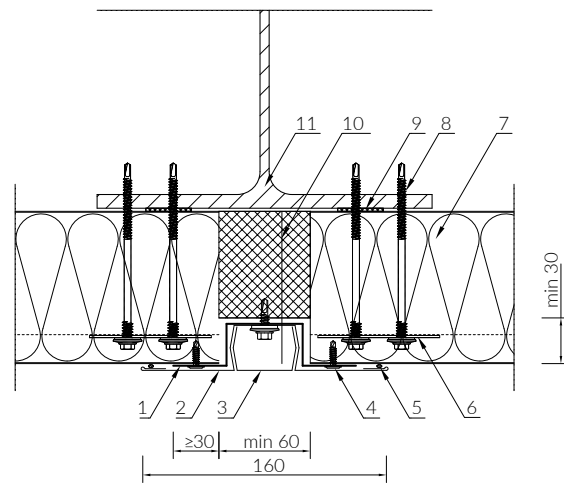

Drawing 11

CORNER WALL PANEL JOINT
 HORIZONTAL PANELS WITH HIDDEN JOINTS LAYOUT

- 1 030.5 flashing
- 2 030.4 flashing
- 3 030.1 flashing
- 4 Self-drilling screw or blind rivet
- 5 Watertight sealing mass*
- 6 Thermal insulation
- 7 Fastener
- 8 SU washer
- 9 PaNELTECH SU wall sandwich panel
- 10 Construction in accordance with building design
- 11 Self adhesive sealant*

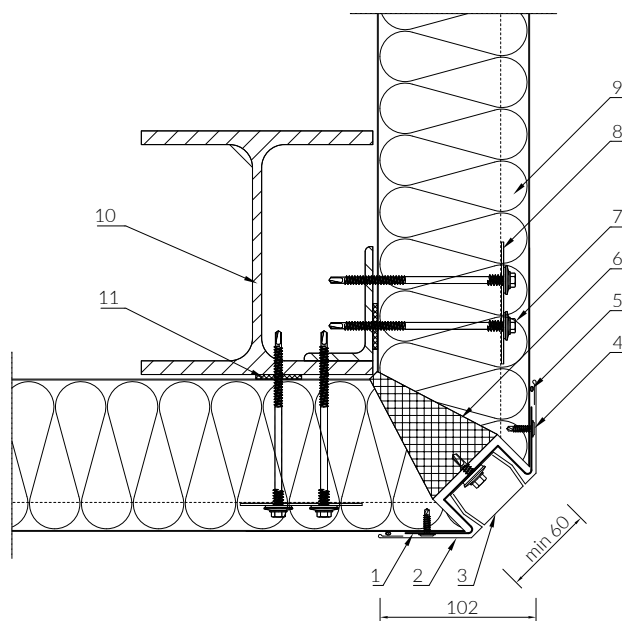

Drawing 12

* as required

WALL PANEL AND MASONRY WALL JOINT
HORIZONTAL PANEL LAYOUT

- 1 Thermal insulation
- 2 Expanding sealant
- 3 O15 flashing
- 4 Self-drilling screw or blind rivet
- 5 Watertight sealing mass in the panel joint*
- 6 Fastener
- 7 PaNELTECH wall sandwich panel
- 8 Self adhesive sealant*
- 9 Construction in accordance with building design
- 10 O20 flashing
- 11 Masonry wall

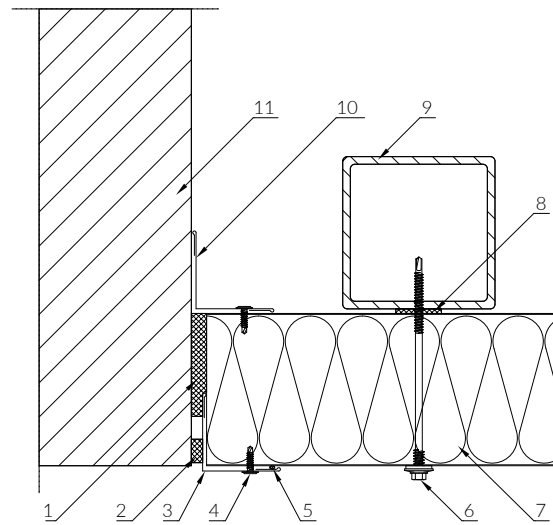

Drawing 13

EXPANDING WALL PANEL JOINT
VERTICAL PANEL LAYOUT

- 1 Self adhesive sealant*
- 2 Thermal insulation
- 3 Construction in accordance with building design
- 4 Fastener
- 5 O01 flashing
- 6 PaNELTECH wall sandwich panel

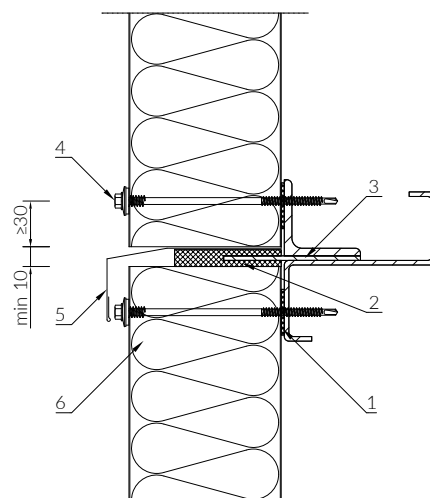

Drawing 14

* as required

GATE OPENING - LINTEL

HORIZONTAL AND VERTICAL PANEL LAYOUT

- 1 PaNELTECH wall sandwich panel
- 2 Watertight sealing mass
- 3 Self-drilling screw or blind rivet
- 4 Fastener
- 5 O05 flashing
- 6 O15 flashing
- 7 O47 flashing (view)
- 8 Self adhesive sealant*
- 9 O46 flashing
- 10 Construction in accordance with building design
- 11 Sectional gate

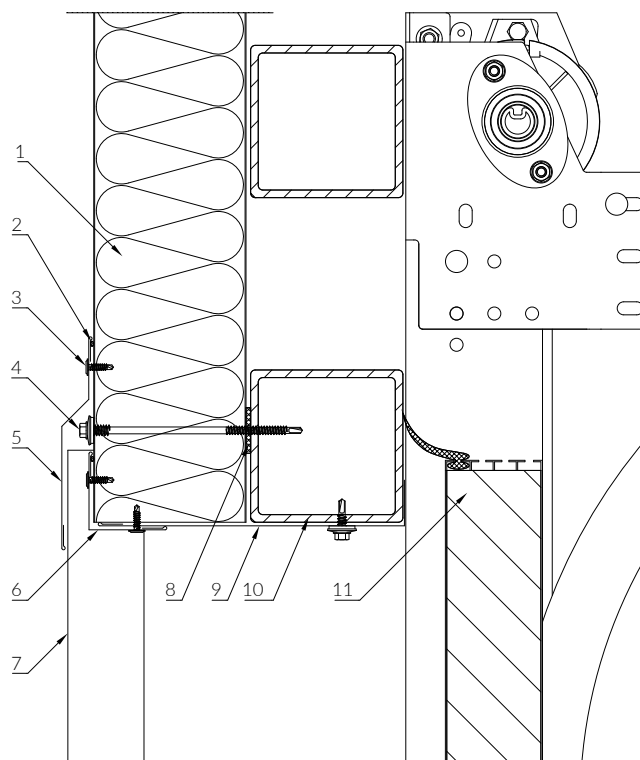

Drawing 15

GATE OPENING - SIDE

HORIZONTAL AND VERTICAL PANEL LAYOUT

- 1 PaNELTECH wall sandwich panel
- 2 Fastener
- 3 O47 flashing
- 4 O46 flashing
- 5 Self adhesive sealant*
- 6 Construction in accordance with building design
- 7 Self-drilling screw or blind rivet
- 8 Sectional gate

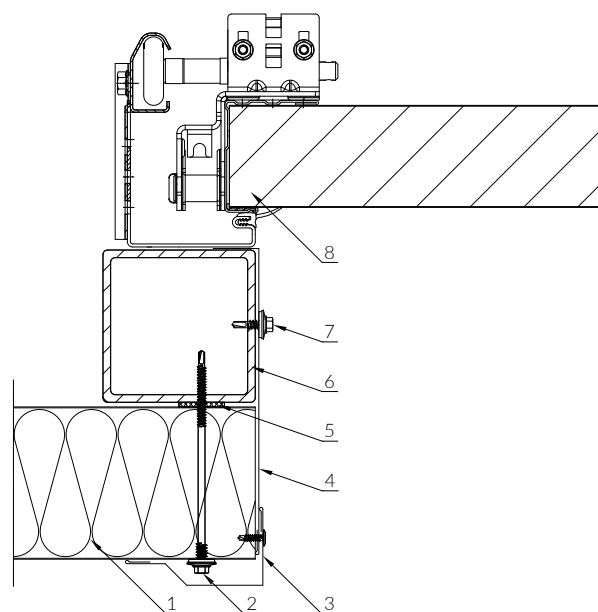

Drawing 16

* as required

GATE OPENING - LINTEL

HORIZONTAL AND VERTICAL PANEL LAYOUT

- 1 PaNELTECH wall sandwich panel
- 2 Construction in accordance with building design
- 3 Self adhesive sealant*
- 4 Fastener
- 5 Self-drilling screw or blind rivet
- 6 Watertight sealing mass
- 7 O05 flashing
- 8 O15 flashing
- 9 O15 flashing (view)
- 10 O46 flashing
- 11 Thermal insulation
- 12 Sectional gate

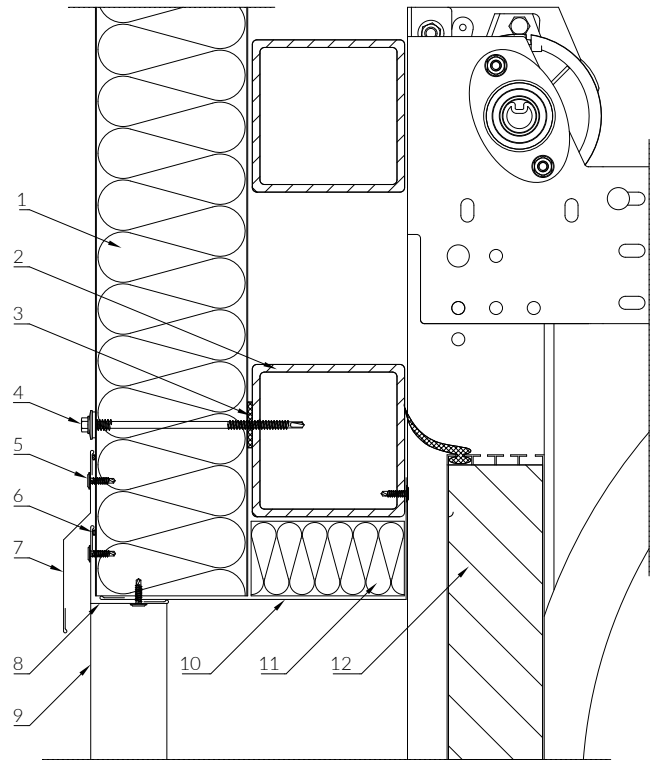

Drawing 17

GATE OPENING - SIDE

HORIZONTAL AND VERTICAL PANEL LAYOUT

- 1 Self adhesive sealant*
- 2 Construction in accordance with building design
- 3 PaNELTECH wall sandwich panel
- 4 Fastener
- 5 Self-drilling screw or blind rivet
- 6 O15 flashing
- 7 O16 flashing
- 8 Thermal insulation
- 9 Sectional gate

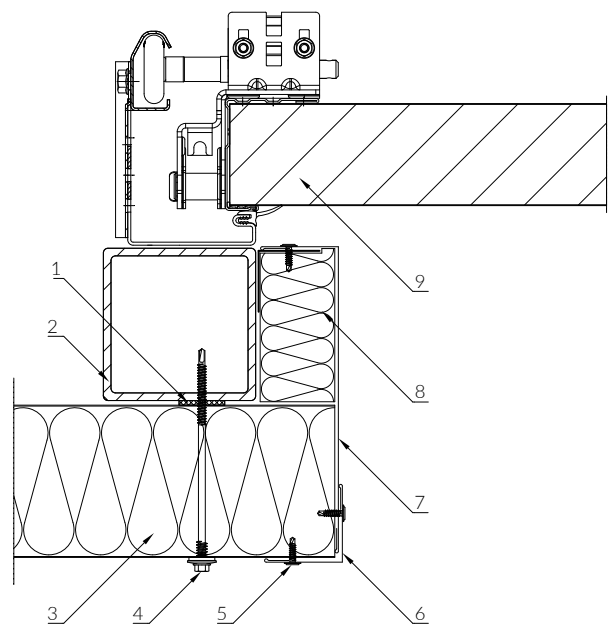

Drawing 18

* as required

WINDOW OPENING - VERTICAL CROSS-SECTION
HORIZONTAL AND VERTICAL PANEL LAYOUT

- 1 Fastener
- 2 Watertight sealing mass
- 3 O09 flashing
- 4 PaNELTECH wall sandwich panel
- 5 O55 B flashing
- 6 O56 B, O57 B or O58 B flashing (view)
- 7 Self-drilling screw or blind rivet
- 8 O51 flashing
- 9 O52 flashing
- 10 Self adhesive sealant*
- 11 Construction in accordance with building design
- 12 Window
- 13 O20 flashing

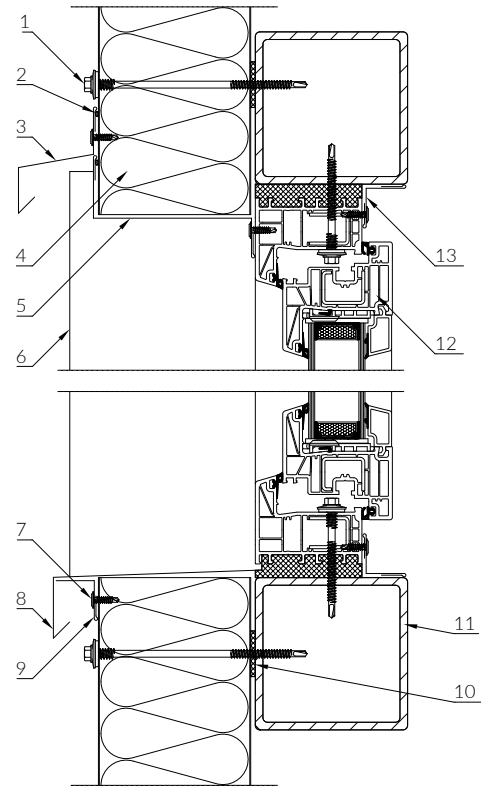

Drawing 19

WINDOW OPENING - HORIZONTAL CROSS-SECTION
HORIZONTAL AND VERTICAL PANEL LAYOUT

- 1 PaNELTECH wall sandwich panel
- 2 Self-drilling screw or blind rivet
- 3 Fastener
- 4 O58 B flashing
- 5 O51 flashing (view)
- 6 Watertight sealing mass
- 7 O20 flashing
- 8 Window
- 9 Construction in accordance with building design
- 10 Self adhesive sealant*
- 11 O56 B flashing

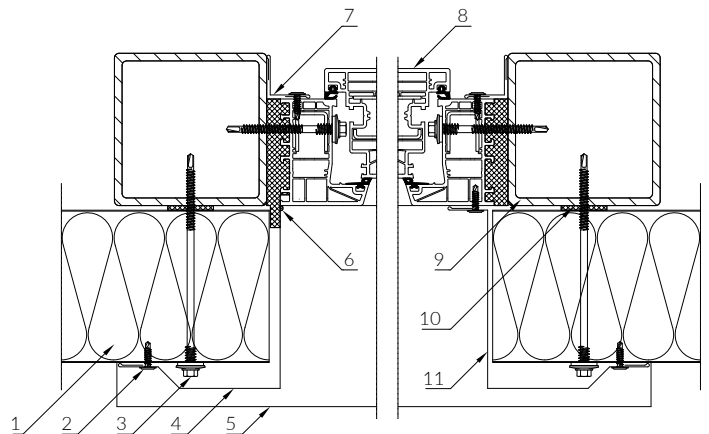

Drawing 20

* as required

WINDOW OPENING - VERTICAL CROSS-SECTION
 HORIZONTAL AND VERTICAL PANEL LAYOUT

- 1 Watertight sealing mass
- 2 Fastener
- 3 O06 flashing
- 4 O21 flashing x 2
- 5 O16 flashing (view)
- 6 Self-drilling screw or blind rivet
- 7 O51 flashing
- 8 O52 flashing
- 9 PaNELTECH wall sandwich panel
- 10 Self adhesive sealant*
- 11 Construction in accordance with building design
- 12 Window
- 13 O12 flashing
- 14 Anchor

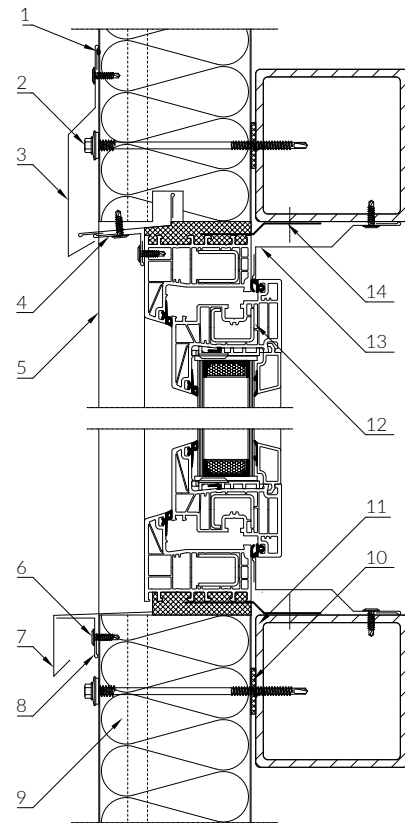

Drawing 21

WINDOW OPENING - HORIZONTAL CROSS-SECTION
 HORIZONTAL AND VERTICAL PANEL LAYOUT

- 1 PaNELTECH wall sandwich panel
- 2 Self-drilling screw or blind rivet
- 3 Fastener
- 4 O56 B flashing
- 5 O51 flashing (view)
- 6 Window
- 7 Watertight sealing mass
- 8 O16 flashing
- 9 Anchor
- 10 O12 flashing
- 11 O26 flashing
- 12 Construction in accordance with building design
- 13 Self adhesive sealant*

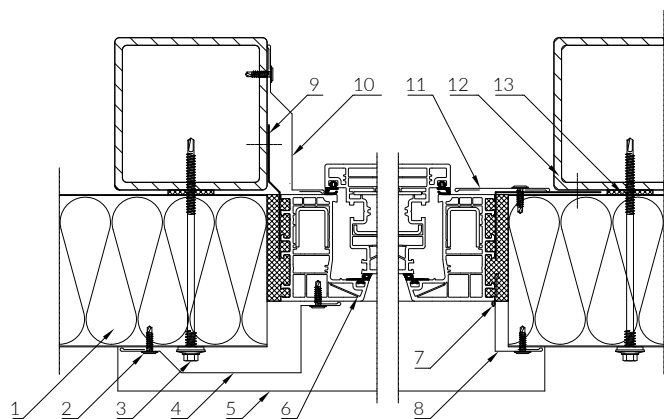

Drawing 22

* as required

COLDROOM SANDWICH PANELS

COLDROOM SANDWICH PANEL

PWPIR-CH

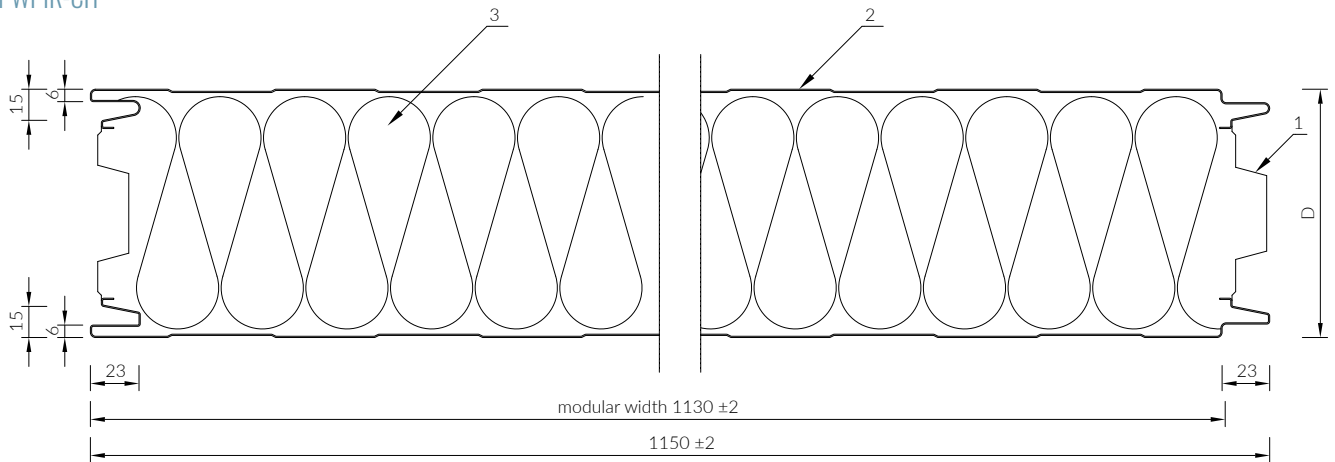

1 Core tapering

2 Steel facing

3 PIR core

D - panel thickness

The standard modular width of 1130 mm can be optionally changed to 1000 or 1050 mm.

COLDROOM PANEL INSTALLATION

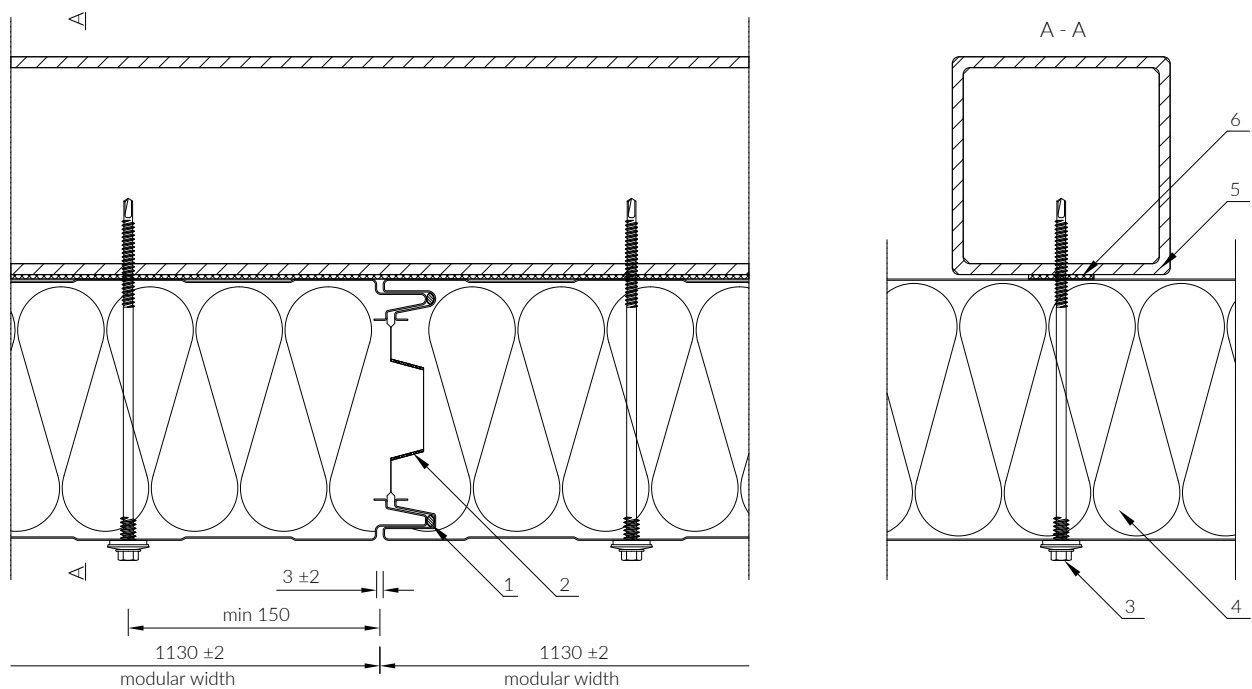

1 Sealing mass

2 Sealing foam (as required)

3 Fastener

4 PaNELTECHwall sandwich panel

5 Construction in accordance with building design

6 Self adhesive sealant

Select the fastener according to the type and thickness of the construction (steel, wood, reinforced concrete, etc.) and the function of the partition. The number of fasteners is specified in the characteristic loading tables. The self-adhesive sealant should be used as required.

JOINT OF EXTERNALLY COMPATIBLE
PWPIR-CH AND PWW-S / PWS-S WALL SANDWICH PANELS

CONFIGURATION 1.
PWPIR-CH TONGUE, PWW-S / PWS-S GROOVE

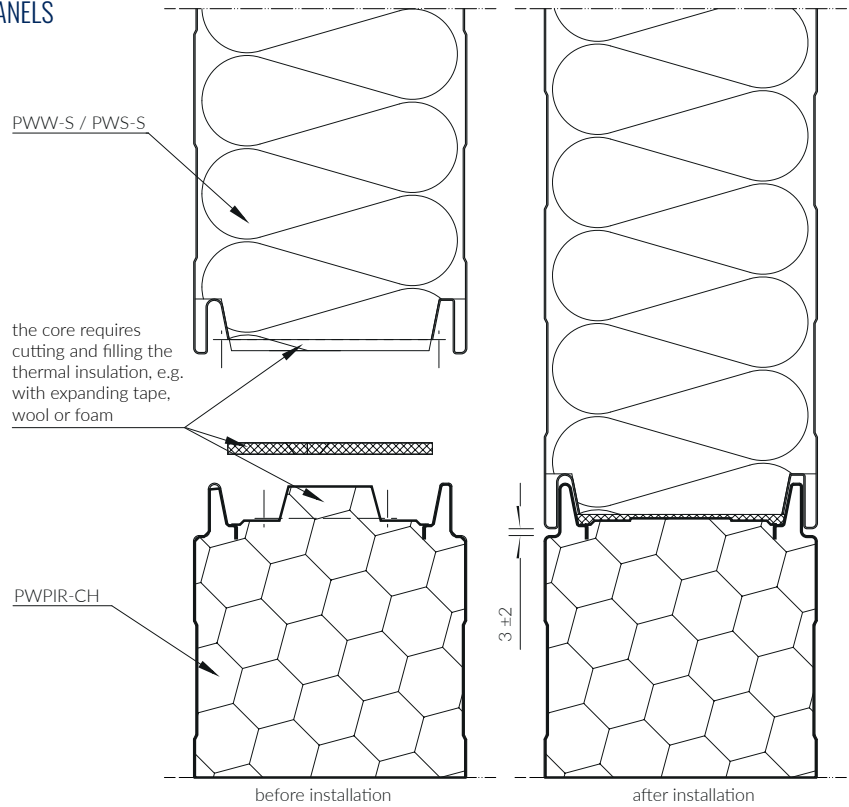

JOINT OF EXTERNALLY COMPATIBLE
PWPIR-CH AND PWW-S / PWS-S WALL SANDWICH PANELS

CONFIGURATION 2.
PWW-S / PWS-S TONGUE, PWPIR-CH GROOVE

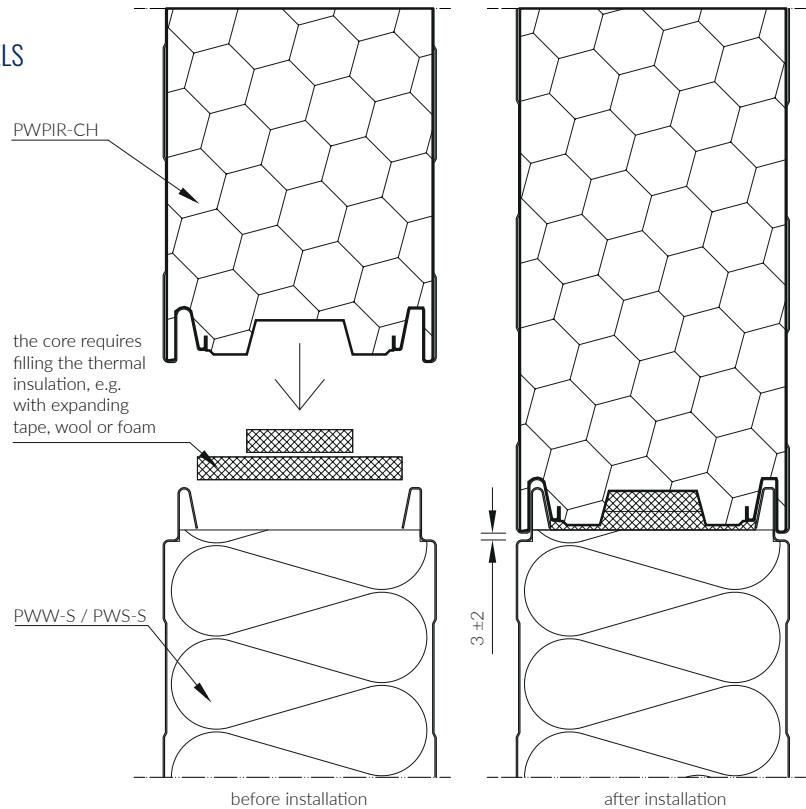

STEEL TIE FOR COLDROOM PANELS

WALL AND CEILING

- 1 Stainless steel fastener Fastener * with a 19 mm washer and an EPDM gasket
- 2 PaNELTECH coldroom sandwich panel
- 3 Self adhesive sealant*
- 4 Construction in accordance with building design

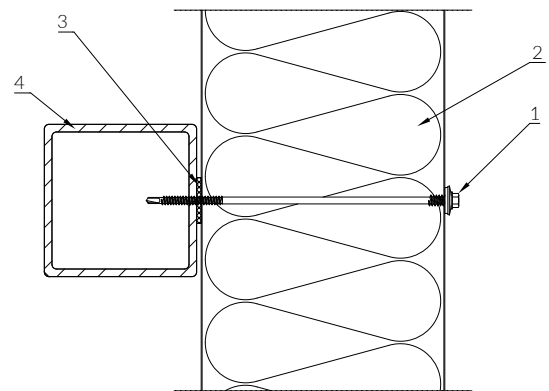

Drawing 23

SWAL LAX TIE FOR COLDROOM PANELS

WALL AND CEILING

- 1 SWAL LAX fastener
- 2 LAX EPDM gasket
- 3 LAX clip
- 4 PaNELTECH coldroom sandwich panel
- 5 Self adhesive sealant*
- 6 SWAL tie with a 16 mm washer and an EPDM gasket
- 7 Construction in accordance with building design

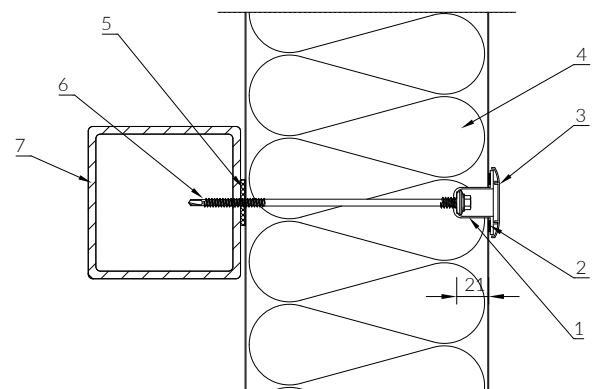

Drawing 24

CASTEL COOL SCREW FOR COLDROOM PANELS

WALL AND CEILING

- 1 CASTEL COOL washer
- 2 Watertight sealing mass
- 3 CASTEL COOL cap
- 4 PaNELTECH coldroom sandwich panel
- 5 Self adhesive sealant*
- 6 Nut with washer
- 7 Steel, galvanized threaded bar
- 8 Construction in accordance with building design

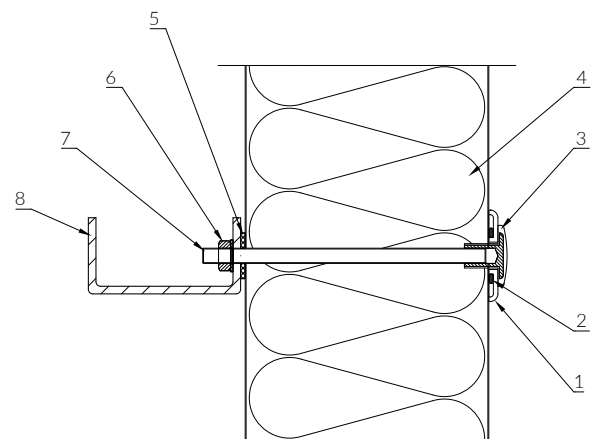

Drawing 25

* as required

COLDROOM EXTERNAL WALL PANEL AND FLOOR JOINT
COLD AND FREEZER ROOM

- 1 Thermal insulation of the ground beam
- 2 001 flashing
- 3 Construction in accordance with building design
- 4 Self adhesive sealant*
- 5 PaNELTECH coldroom sandwich panel
- 6 Rounding or finishing element
- 7 Floor
- 8 Vapor barrier
- 9 Facing removed on the construction site
- 10 Thermal insulation
- 11 Thermal insulation of the floor
- 12 Vapor barrier
- 13 Floor heating installation*
- 14 Reinforced concrete slab

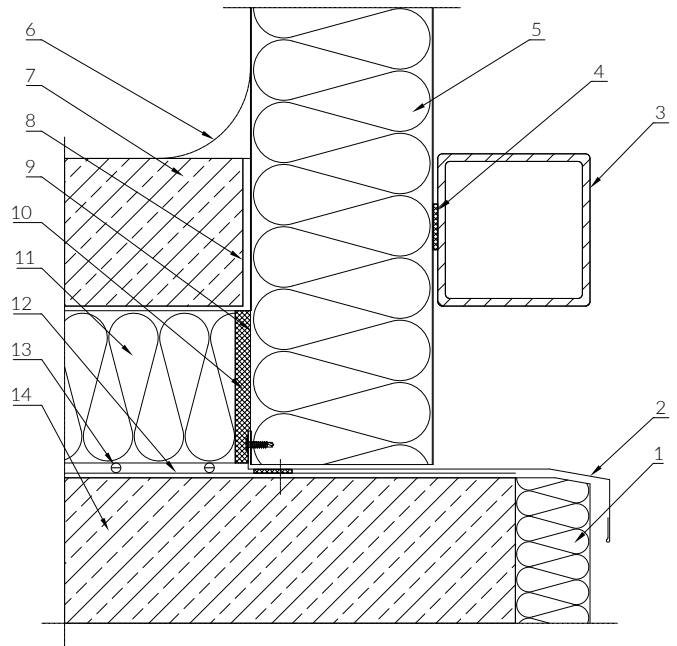

Drawing 26

COLDROOM EXTERNAL WALL PANEL AND FLOOR JOINT
COLD AND FREEZER ROOM

- 1 External plinth
- 2 PaNELTECH coldroom sandwich panel
- 3 009 flashing
- 4 Self-drilling screw or blind rivet
- 5 Watertight sealing mass
- 6 Rounding or finishing element
- 7 Floor
- 8 Vapor barrier
- 9 Facing removed on the construction site
- 10 Thermal insulation
- 11 Floor heating installation*
- 12 Thermal insulation of the floor
- 13 Vapor barrier
- 14 Reinforced concrete slab

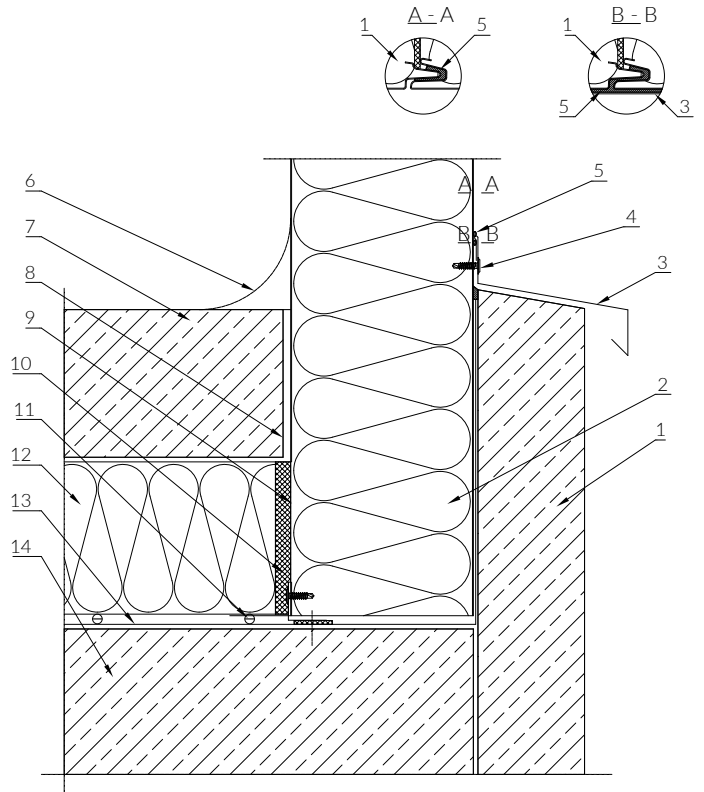

Drawing 27

* as required

COLDROOM INTERNAL WALL PANEL AND FLOOR JOINT
COLD AND FREEZER ROOM

- 1 Self-drilling screw or blind rivet
- 2 O15 flashing
- 3 PaNELTECH coldroom sandwich panel
- 4 Vapor barrier
- 5 Floor
- 6 Rounding or finishing element
- 7 Facing removed on the construction site
- 8 Thermal insulation
- 9 Floor heating installation*
- 10 Vapor barrier
- 11 Thermal insulation of the floor
- 12 Reinforced concrete slab

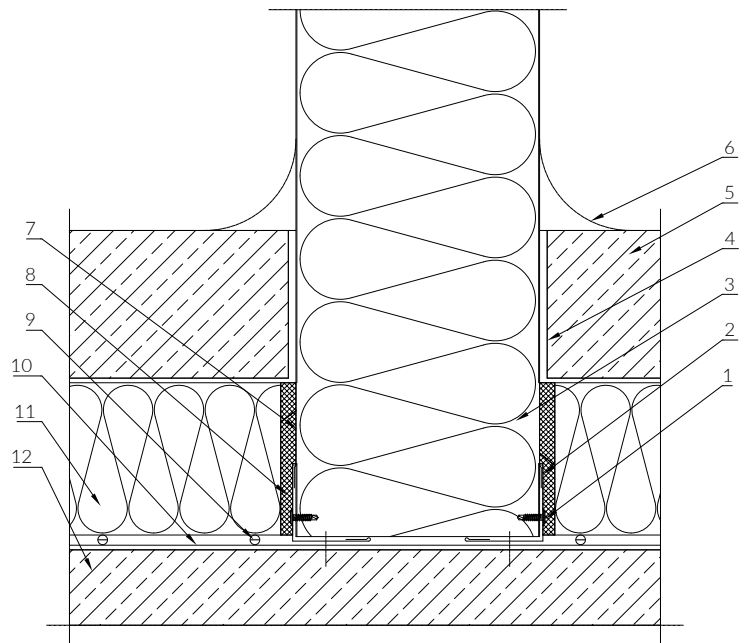

Drawing 28

COLDROOM PANEL AND FLOOR JOINT FINISH
COLDROOM

- 1 Reinforced concrete slab
- 2 Concrete plinth in accordance with building design
- 3 CASTEL COOL finishing profile
- 4 PaNELTECH coldroom sandwich panel
- 5 Vapor barrier
- 6 O16 flashing
- 7 Self-drilling screw or blind rivet
- 8 Floor rounding

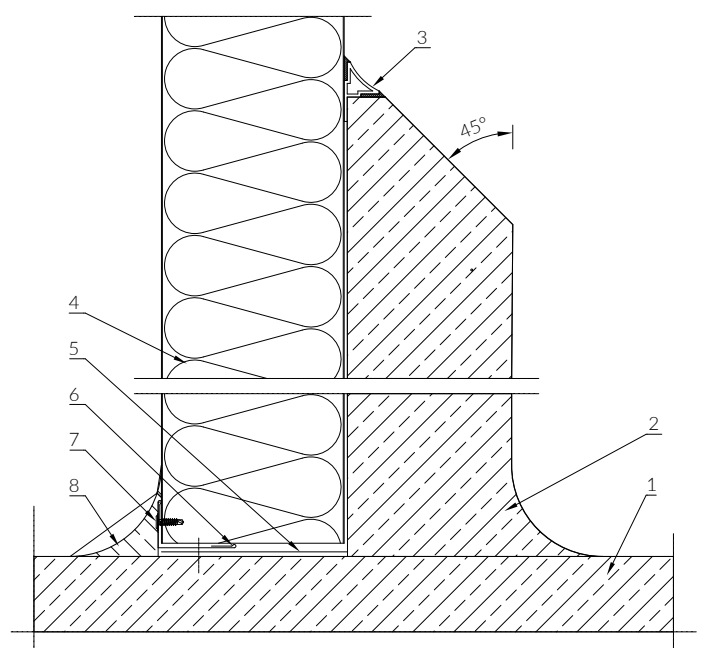

Drawing 29

* as required

COLDROOM PANEL AND FLOOR JOINT FINISH

- 1 Reinforced concrete slab
- 2 Watertight sealing mass
- 3 O25 flashing
- 4 Vapor barrier
- 5 PaNELTECH coldroom sandwich panel
- 6 Self-drilling screw or blind rivet
- 7 O24 flashing
- 8 Watertight sealing mass

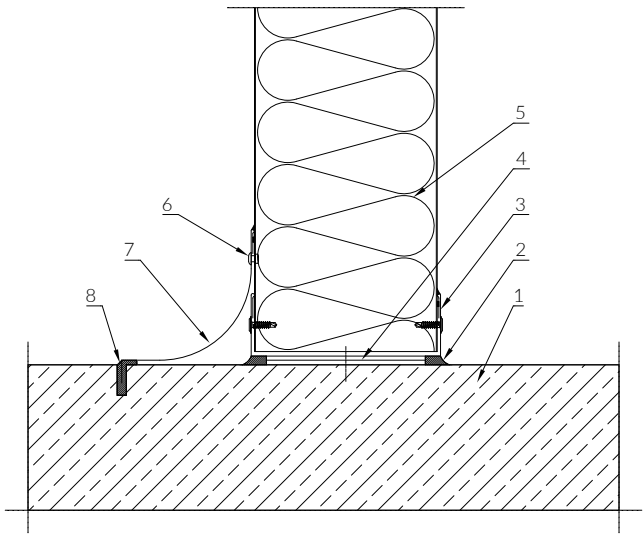

Drawing 30

COLDROOM PANEL AND FLOOR JOINT FINISH

- 1 Reinforced concrete slab
- 2 O22 flashing
- 3 Stainless self-drilling screw
- 4 Vapor barrier
- 5 PaNELTECH coldroom sandwich panel
- 6 Self-drilling screw or sealed rivet
- 7 O15 flashing
- 8 O23 flashing
- 9 Watertight sealing mass
- 10 Ceramic tiles

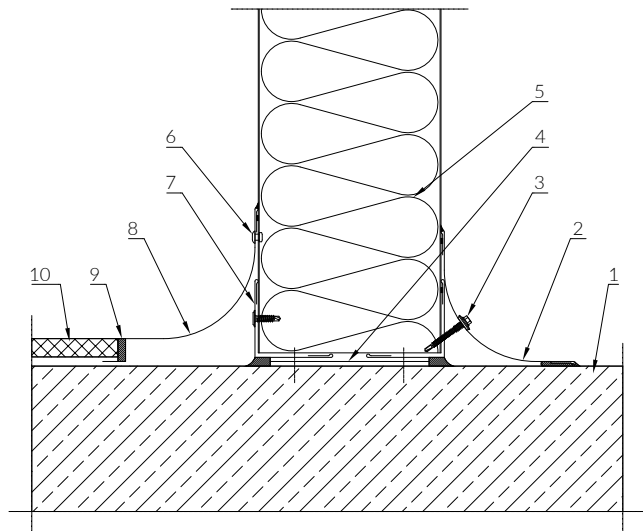

Drawing 31

COLDROOM PANEL AND FLOOR JOINT FINISH

- 1 Reinforced concrete slab
- 2 PVC starting profile, type U
- 3 Watertight sealing mass
- 4 PaNELTECH coldroom sandwich panel
- 5 Self-drilling screw or blind rivet
- 6 PVC plinth profile

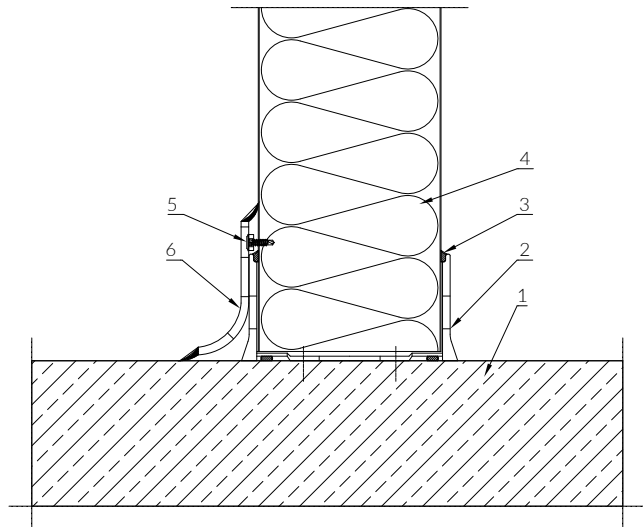

Drawing 32

INTERNAL CORNER FINISHING

- 1 PaNELTECH coldroom sandwich panel

- 2 Watertight sealing mass

- 3 O20 flashing

- 4 Self-drilling screw or sealed rivet

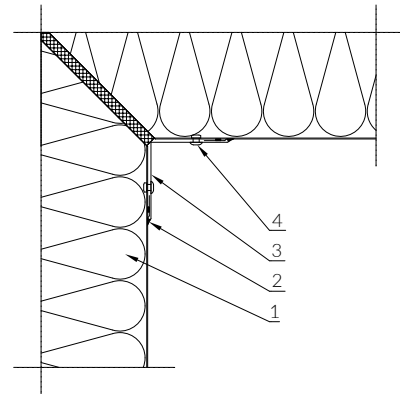

Drawing 33

INTERNAL CORNER FINISHING

- 1 PaNELTECH coldroom sandwich panel

- 2 Watertight sealing mass

- 3 Self-drilling screw or sealed rivet

- 4 O22 flashing

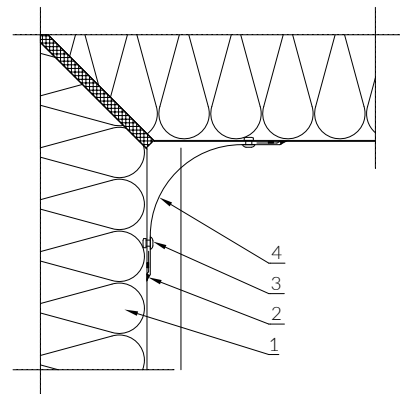

Drawing 34

INTERNAL CORNER FINISHING

- 1 PaNELTECH coldroom sandwich panel

- 2 Rounded PVC corner profile

- 3 Self-drilling screw or sealed rivet

- 4 Watertight sealing mass

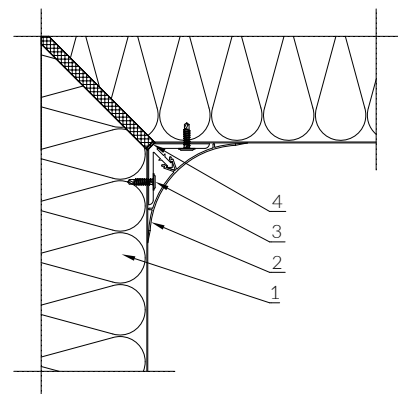

Drawing 35

WALL AND CEILING JOINT
COLD AND FREEZERROOM

- 1 Wall - PaNELTECH sandwich panel
- 2 O20 flashing
- 3 Self-drilling screw or blind rivet
- 4 Ceiling - PaNELTECH sandwich panel
- 5 Facing removed on the construction site
- 6 Thermal insulation
- 7 Watertight sealing mass
- 8 O16 flashing

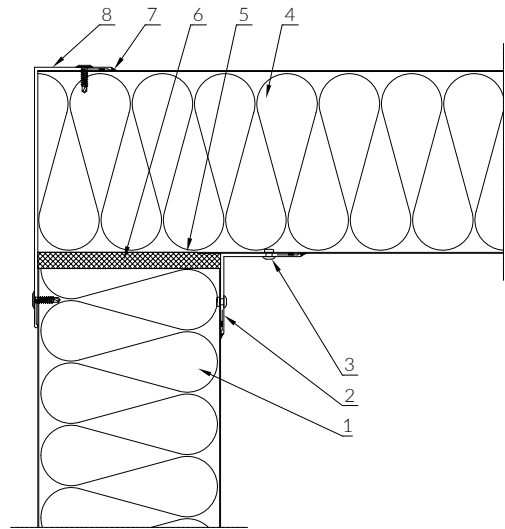

Drawing 36

WALL AND CEILING JOINT
COLD AND FREEZERROOM

- 1 Wall - PaNELTECH sandwich panel
- 2 O20 flashing
- 3 Self-drilling screw or blind rivet
- 4 Ceiling - PaNELTECH sandwich panel
- 5 Facing removed on the construction site
- 6 Thermal insulation
- 7 Watertight sealing mass
- 8 O16 flashing

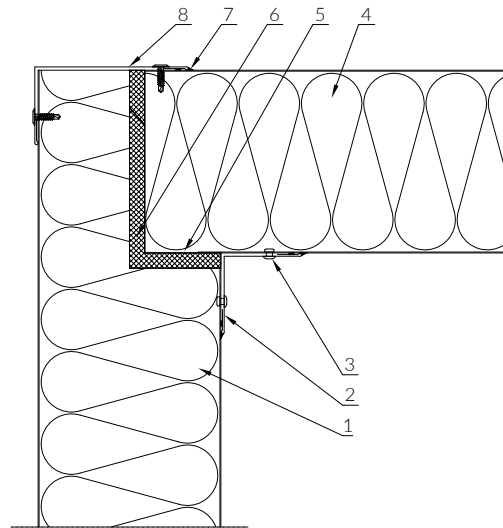

Drawing 37

WALL AND CEILING JOINT
COLD AND FREEZERROOM

- 1 Wall - PaNELTECH sandwich panel
- 2 O20 flashing
- 3 Self-drilling screw or blind rivet
- 4 Ceiling - PaNELTECH sandwich panel
- 5 Facing removed on the construction site
- 6 Thermal insulation
- 7 Watertight sealing mass
- 8 O26 flashing
- 9 Ceiling - PaNELTECH sandwich panel

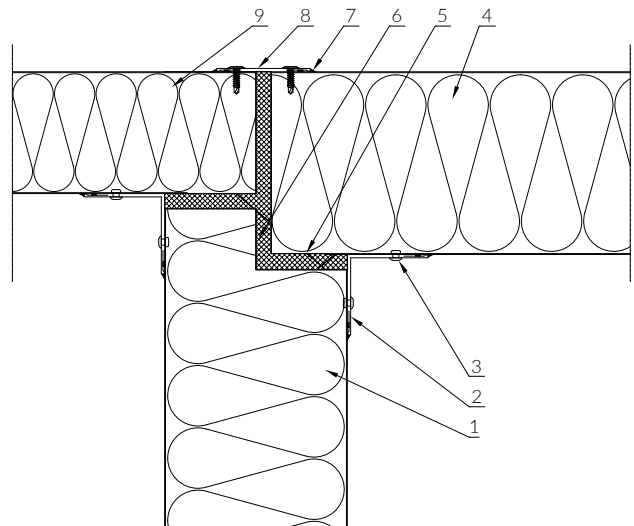

Drawing 38

CEILING SUSPENDED ON A WALL PANEL
COLD AND FREEZERROOM

- 1 Stainless steel acorn cap
- 2 Stainless steel washer
- 3 Watertight sealing mass
- 4 Ceiling - PaNELTECH sandwich panel
- 5 Nut
- 6 Threaded rod made of stainless steel

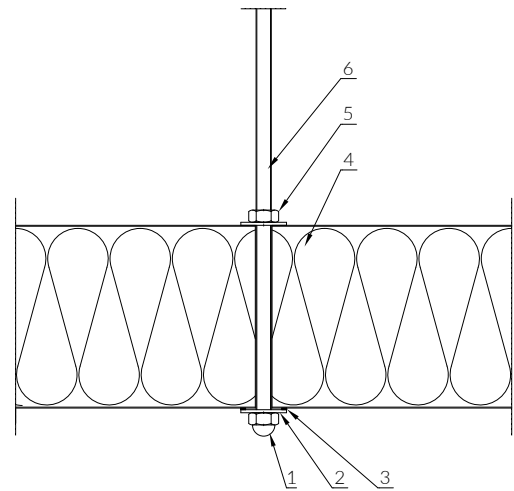

Drawing 39

CEILING SUSPENDED ON A WALL PANEL
COLD AND FREEZERROOM

- 1 Ceiling - PaNELTECH sandwich panel
- 2 Self-drilling screw or blind rivet
- 3 Stainless steel fastener* with a 19 mm washer and an EPDM seal
- 4 O28 flashing
- 5 Watertight sealing mass
- 6 Self adhesive sealant*
- 7 Construction in accordance with building design
- 8 Thermal insulation

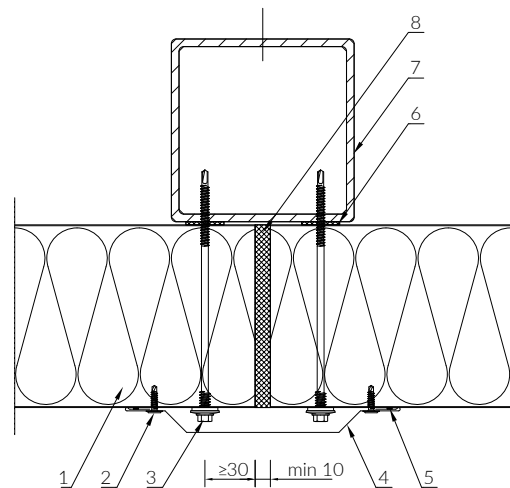

Drawing 40

CEILING SUSPENDED ON A WALL PANEL
COLD AND FREEZERROOM

- 1 Ceiling - PaNELTECH sandwich panel
- 2 Self-drilling screw or blind rivet
- 3 Omega-profiled washer
- 4 Cap
- 5 Omega profile
- 6 Watertight sealing mass
- 7 Thermal insulation
- 8 Threaded bar
- 9 O26 flashing
- 10 Watertight sealing mass

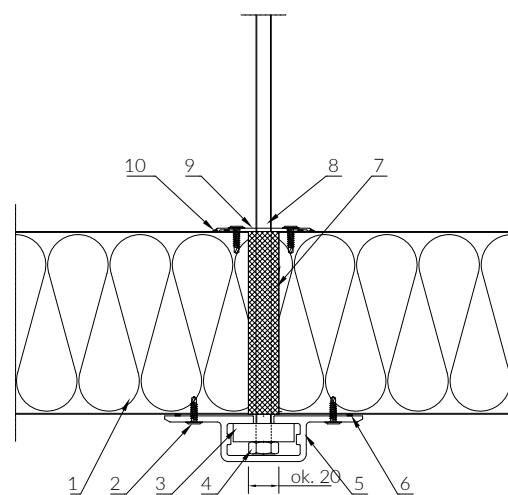

Drawing 41

* as required

COLDROOM DOOR INSTALLED IN A WALL PANEL

LINTEL AND SIDE

- 1 Coldroom door leaf
- 2 Coldroom door leaf seal
- 3 Masking clip
- 4 Door frame with a heating cable*
- 5 PaNELTECH wall sandwich panel
- 6 CASTEL COOL fastener
- 7 Door opening flashing

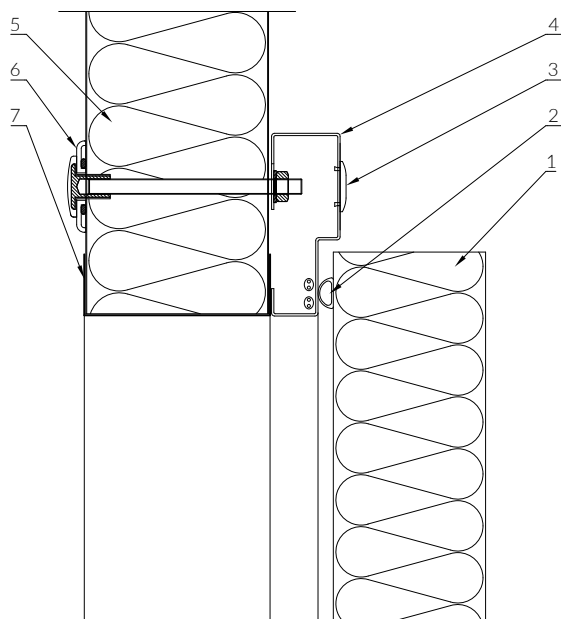

Drawing 42

COLDROOM DOOR INSTALLED IN A WALL PANEL

THRESHOLD

- 1 Coldroom door leaf seal
- 2 Coldroom door leaf
- 3 Door opening flashing view
- 4 Threshold with a heating cable*
- 5 Cold store floor

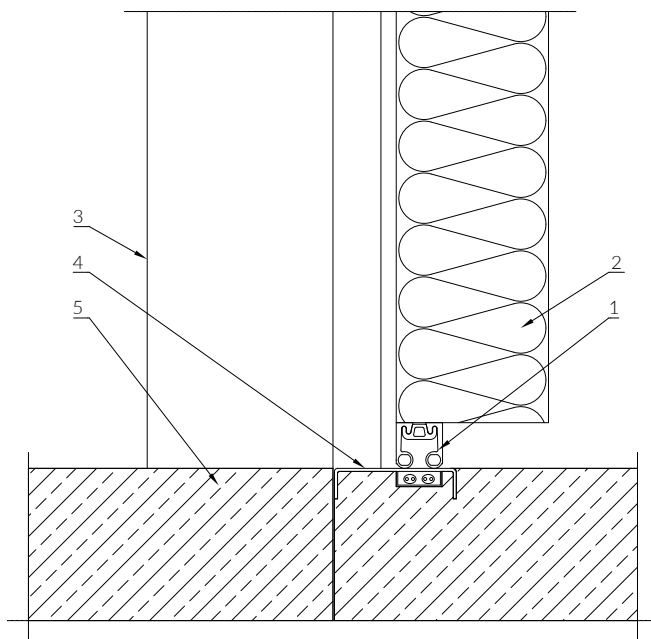

Drawing 43

* as required

ROOF SANDWICH PANELS

ROOF SANDWICH PANEL

PWPIR-D

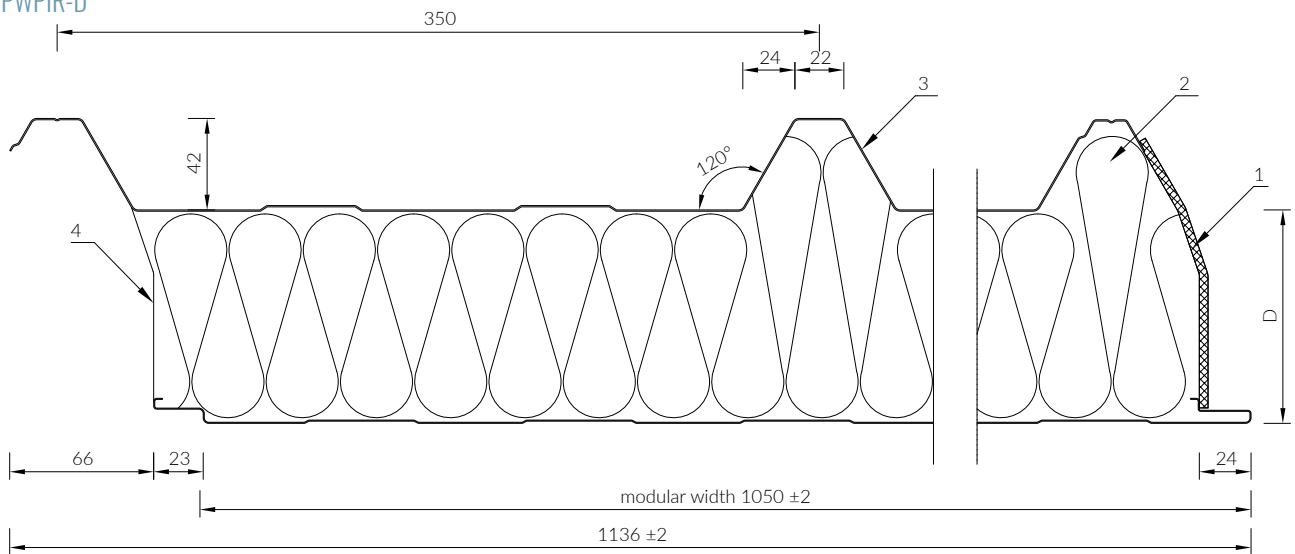

- 1 Polyurethane seal
 - 2 PIR core
 - 3 Steel facing
 - 4 Aluminum protective foil
- D - panel thickness

ROOF PANEL INSTALLATION

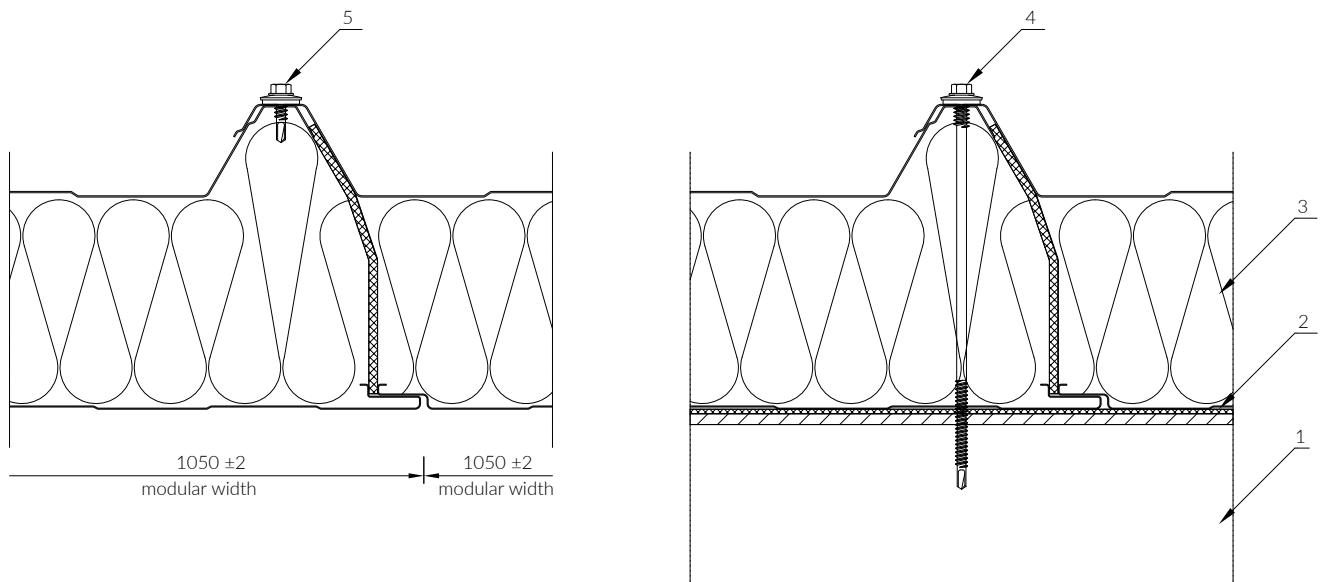

- 1 Construction in accordance with building design
- 2 Self adhesive sealant
- 3 PaNELTECH roof sandwich panel
- 4 fastener
- 5 Self-drilling screw with a seal every ca. 300-400 mm

Select the tie according to the type and thickness of the underlying structure (steel, wood, reinforced concrete, etc.) and the function of the partition. The number of fasteners is specified in the characteristic loading tables. The self-adhesive sealant should be used as required.

ROOF SANDWICH PANEL
PWS-D / PWW-D

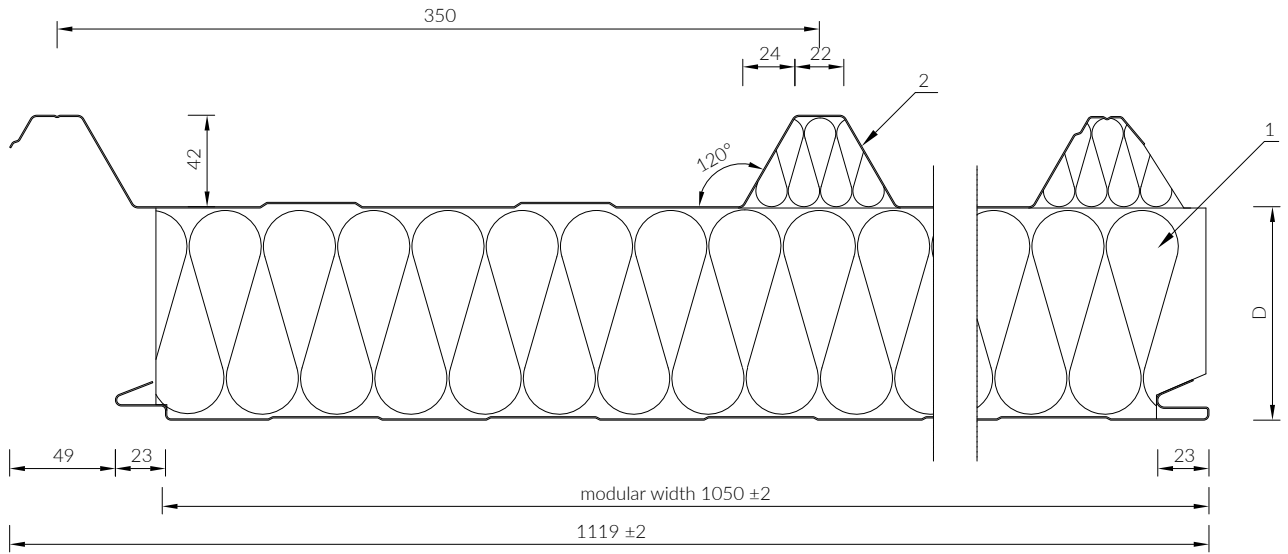

- 1 EPS or mineral wool core
- 2 Steel facing
- D - panel thickness

ROOF PANEL INSTALLATION

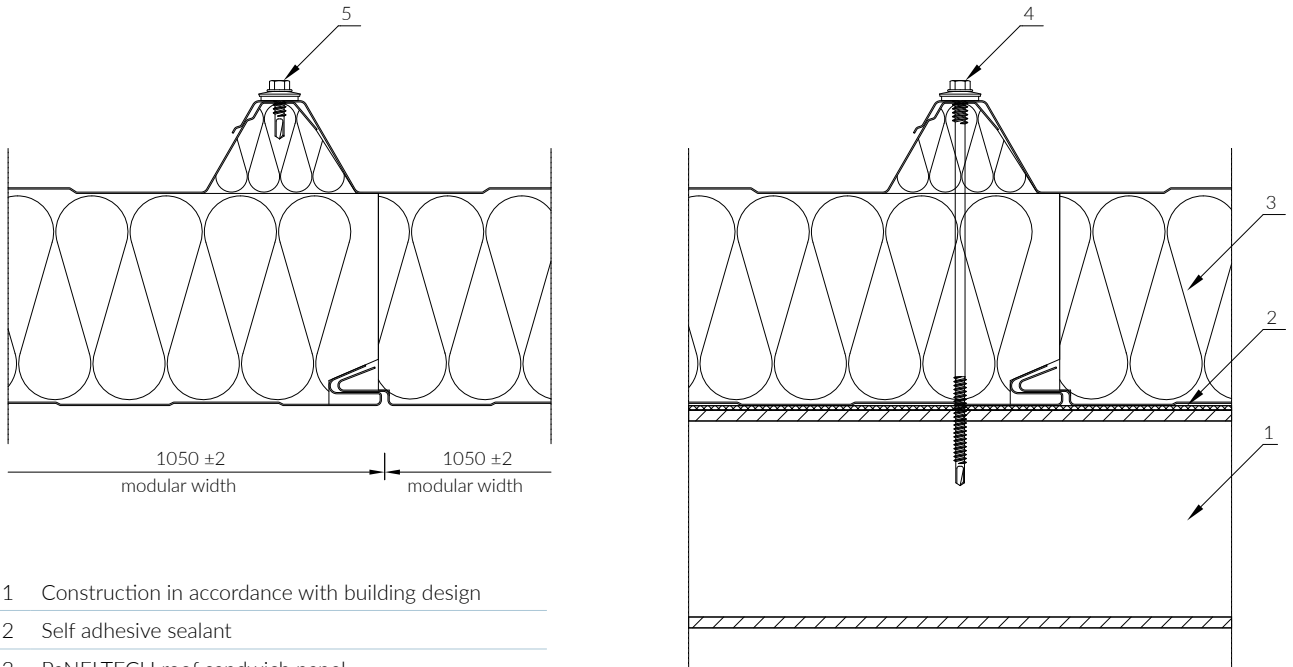

- 1 Construction in accordance with building design
- 2 Self adhesive sealant
- 3 PaNELTECH roof sandwich panel
- 4 fastener
- 5 Self-drilling screw with a seal every ca. 300-400 mm

Select the tie according to the type and thickness of the underlying structure (steel, wood, reinforced concrete, etc.) and the function of the partition. The number of ties is specified in the load tables. The self-adhesive sealant should be used as required.

JOINT OF EXTERNALLY COMPATIBLE PWPIR-D AND PWW-D / PWS-D ROOF SANDWICH PANELS
 VERSION 1. PWPIR-D ROOF SANDWICH PANEL INSTALLED AS FIRST

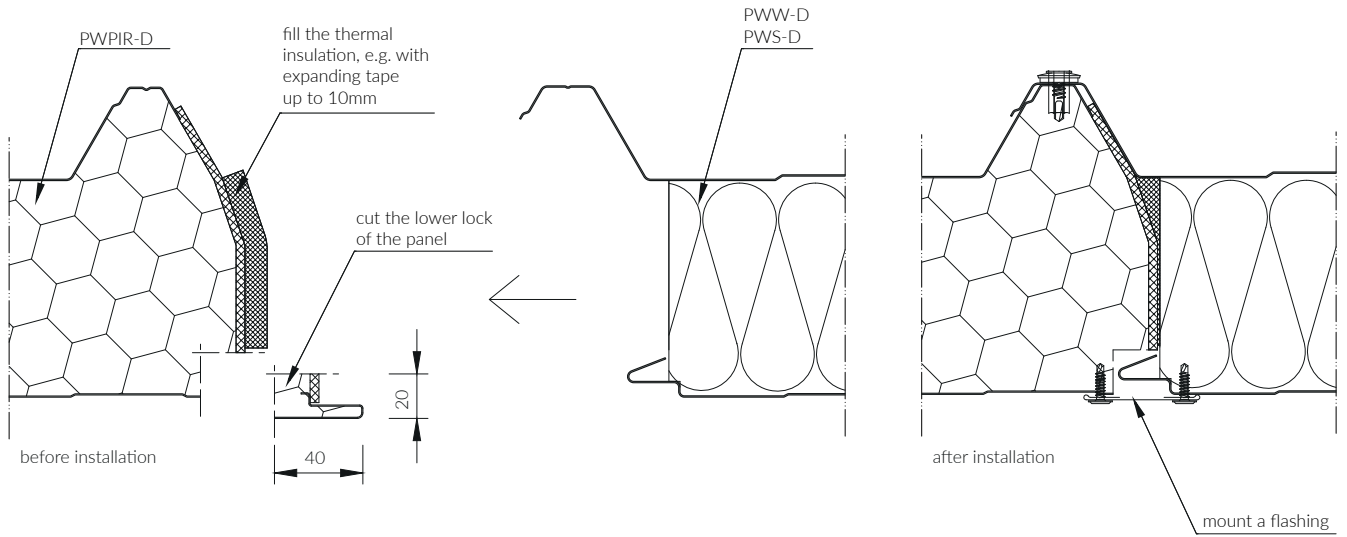

JOINT OF EXTERNALLY COMPATIBLE PWPIR-D AND PWW-D / PWS-D ROOF SANDWICH PANELS
 VERSION 1. PWW-D / PWS-D ROOF SANDWICH PANEL INSTALLED AS FIRST

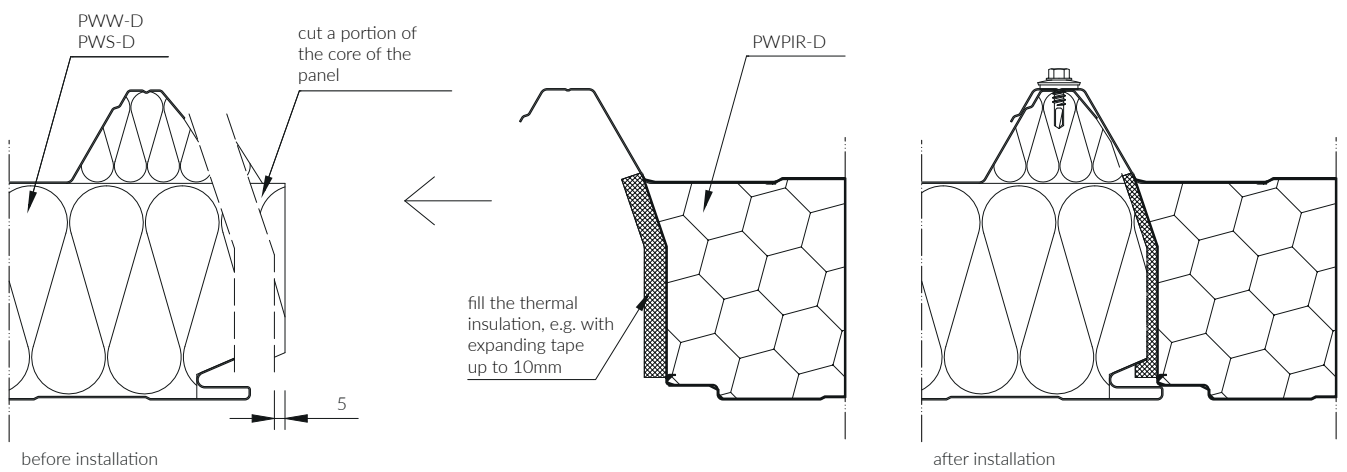

ROOF PANEL JOINT

RIDGE

- 1 103 flashing
- 2 Thermal insulation
- 3 Self adhesive sealant*
- 4 Construction in accordance with building design
- 5 PaNELTECH roof sandwich panel
- 6 102 flashing
- 7 Self-drilling screw with a seal
- 8 Facing bending executed at the construction site
- 9 101 flashing
- 10 fastener
- 11 UD42 seal
- 12 Watertight sealing mass / self adhesive sealant*

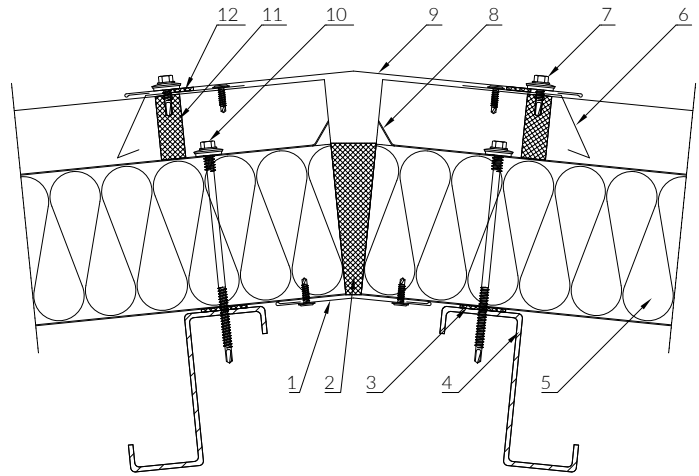

Drawing 44

ROOF PANEL AND WALL PANEL JOINT

GUTTERED EAVES
FOR PANELS WITH THICKNESS ≥ 100 MM

- 1 Gutter system
- 2 130 flashing
- 3 Facing cutting executed at the construction site*
- 4 111 flashing*
- 5 Self-drilling screw with a seal
- 6 PaNELTECH roof sandwich panel with a cutting
- 7 Z42 roof end cap (recommended for flat roofs and PWW-D panels)
- 8 Watertight sealing mass*
- 9 110 flashing

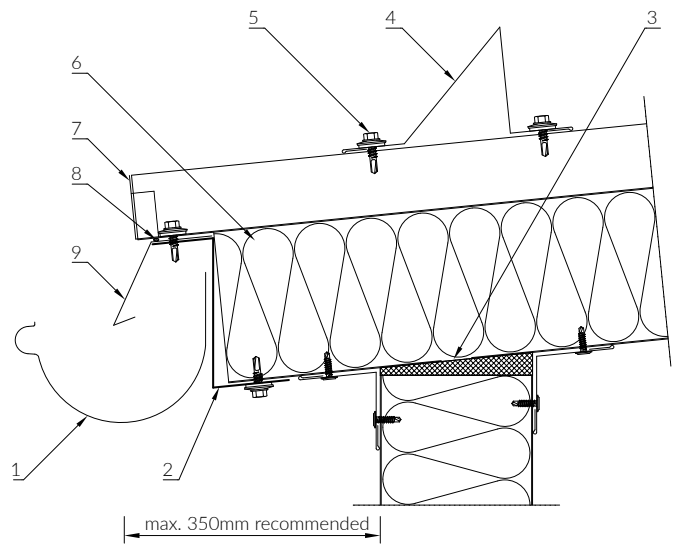

Drawing 45

ROOF PANEL AND WALL PANEL JOINT

GUTTERED EAVES (RECOMMENDED SOLUTION)
FOR 40-80 MM THICK PANELS

- 1 Gutter system
- 2 131 flashing
- 3 O20 flashing
- 4 PaNELTECH wall sandwich panel
- 5 Thermal insulation
- 6 PaNELTECH roof sandwich panel with a cutting
- 7 Watertight sealing mass*
- 8 108 flashing* or Z42 roof end cap (recommended for flat roofs and PWW-D panels)
- 9 110 flashing

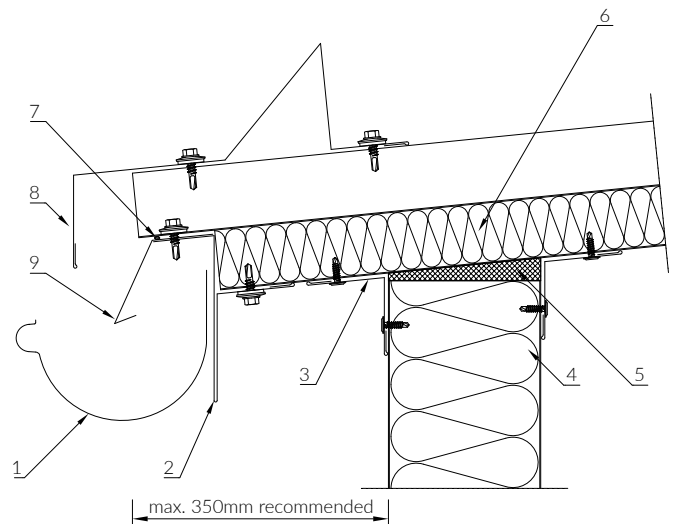

Drawing 46

* as required

ROOF PANEL AND WALL PANEL JOINT

**GUTTERED EAVES (NOT RECOMMENDED SOLUTION)
FOR PANELS WITH THICKNESS ≥ 100 MM**

- 1 Gutter system
- 2 150 flashing
- 3 O20 flashing
- 4 Self-drilling screw or blind rivet
- 5 PaNELTECH wall sandwich panel
- 6 Thermal insulation
- 7 Facing cutting executed at the construction site*
- 8 111 flashing*
- 9 Self-drilling screw with a seal
- 10 PaNELTECH roof sandwich panel without cutting
- 11 Z42 roof end cap (recommended for flat roofs and PWW-D panels)
- 12 Watertight sealing mass*
- 13 110 flashing / B = 120

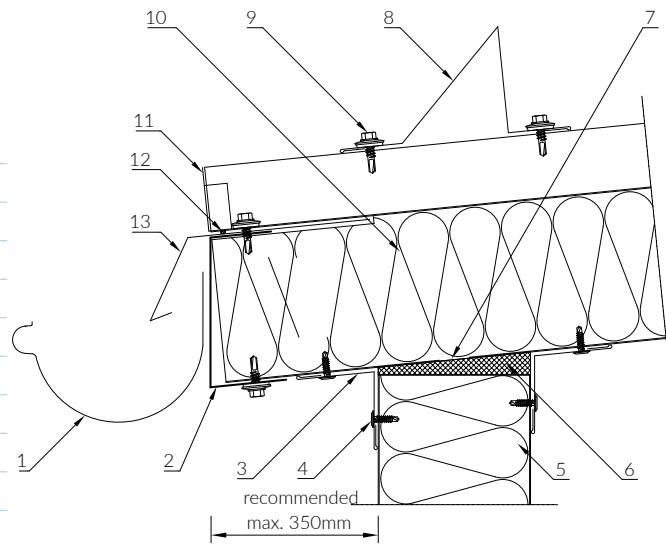

Drawing 47

ROOF PANEL AND WALL PANEL JOINT

**GUTTERED EAVES (NOT RECOMMENDED SOLUTION)
FOR 40-80 MM THICK PANELS**

- 1 Gutter system
- 2 134 flashing
- 3 O20 flashing
- 4 Self-drilling screw or blind rivet
- 5 PaNELTECH wall sandwich panel
- 6 Thermal insulation
- 7 PaNELTECH roof sandwich panel without cutting
- 8 Self-drilling screw with a seal
- 9 111 flashing*
- 10 Z42 roof end cap (recommended for flat roofs and PWW-D panels)
- 11 Watertight sealing mass*
- 13 110 flashing / B = 120

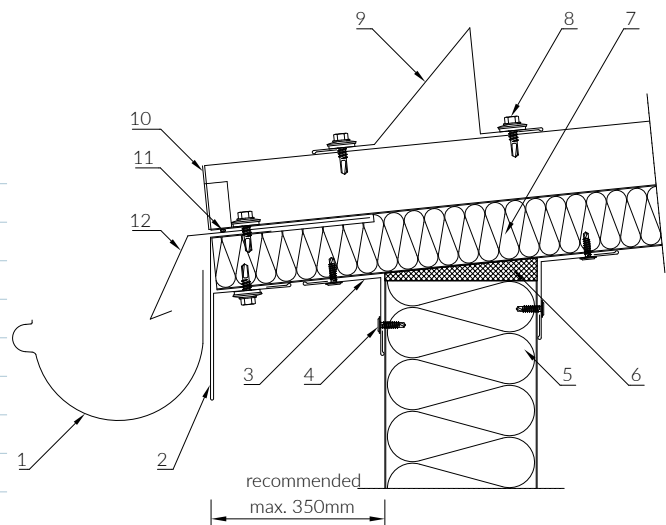

Drawing 48

* as required

EXPANDING ROOF PANEL JOINT

CROSSWISE JOINT

- 1 Construction in accordance with building design
- 2 Self adhesive sealant*
- 3 PaNELTECH roof sandwich panel
- 4 Thermal insulation (expanding tape)
- 5 Fastener
- 6 Watertight sealing mass (e.g. butyl)
- 7 Self-drilling screw with a seal (every ca. 120mm)

z - minimum width of the outermost support

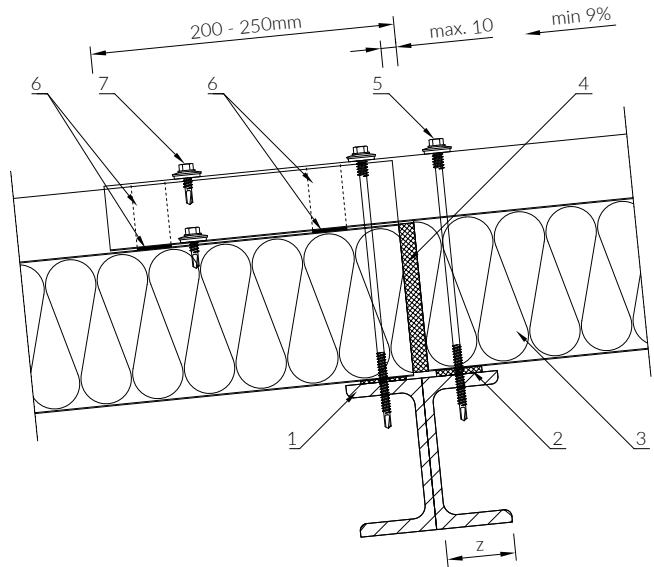

Drawing 49

ROOF PANEL AND WALL PANEL JOINT

SINGLE-SLOPED ROOF EAVES

- 1 O20 flashing
- 2 Self-drilling screw or blind rivet
- 3 PaNELTECH wall sandwich panel
- 4 Thermal insulation
- 5 PaNELTECH roof sandwich panel
- 6 106 flashing
- 7 Watertight sealing mass / self adhesive sealant*
- 8 Self-drilling screw with a seal
- 9 UD42 seal
- 10 102 flashing
- 11 Facing cutting executed at the construction site*

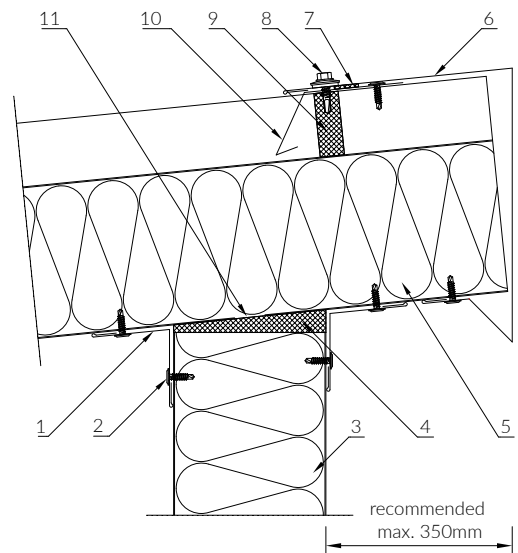

Drawing 50

ROOF PANEL AND WALL PANEL JOINT

EAVELESS SINGLE-SLOPED ROOF

- 1 O20 flashing
- 2 Self-drilling screw or blind rivet
- 3 PaNELTECH wall sandwich panel
- 4 Self-drilling screw with a seal
- 5 Thermal insulation
- 6 Facing cutting executed at the construction site*
- 7 PaNELTECH roof sandwich panel
- 8 104 B flashing
- 9 Watertight sealing mass / self adhesive sealant*
- 10 UD42 seal
- 11 102 flashing

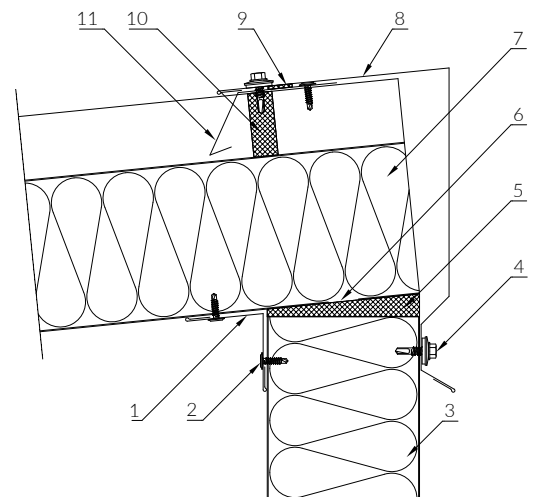

Drawing 51

* as required

ROOF PANEL AND WALL PANEL JOINT

GABLE EAVES

- 1 020 flashing
- 2 Self-drilling screw or blind rivet
- 3 PaNELTECH wall sandwich panel
- 4 Thermal insulation
- 5 107 flashing
- 6 Self-drilling screw with a seal
- 7 PaNELTECH roof sandwich panel
- 8 Facing cutting executed at the construction site*

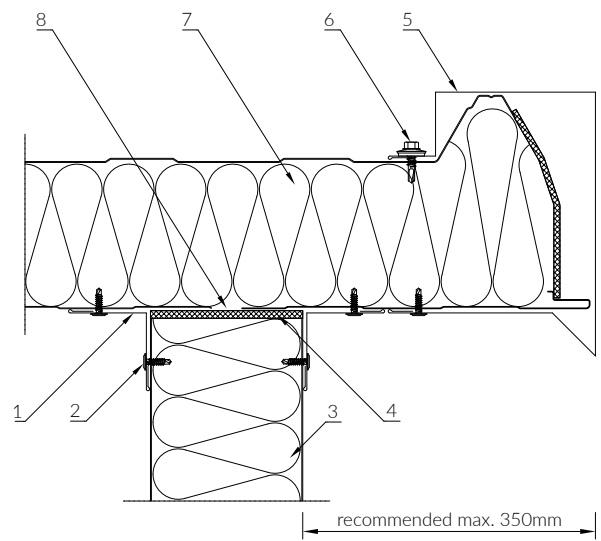

Drawing 52

ROOF PANEL AND WALL PANEL JOINT

EAVELESS GABLE

- 1 020 flashing
- 2 Self-drilling screw or blind rivet
- 3 PaNELTECH wall sandwich panel
- 4 Self-drilling screw with a seal
- 5 Thermal insulation
- 6 Facing cutting executed at the construction site*
- 7 105 B flashing
- 8 PaNELTECH roof sandwich panel

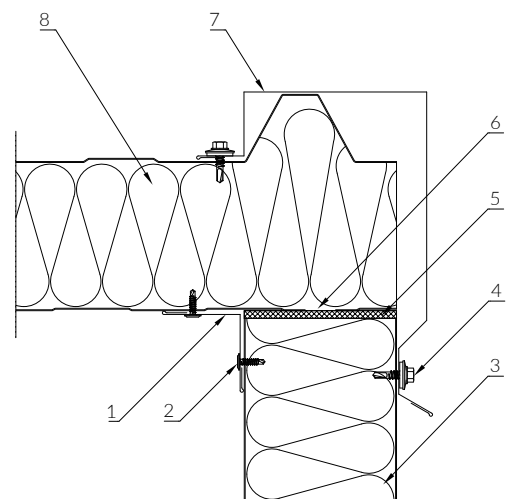

Drawing 53

* as required

ROOF PANEL AND WALL PANEL JOINT
SINGLE-SLOPED ROOF - ATTIC

- 1 PaNELTECH roof sandwich panel
- 2 Construction in accordance with building design
- 3 Self adhesive sealant*
- 4 O20 flashing
- 5 Self-drilling screw or blind rivet
- 6 PaNELTECH wall sandwich panel
- 7 Thermal insulation
- 8 Facing cutting executed at the construction site*
- 9 113 flashing
- 10 114 flashing
- 11 Facing bending executed at the construction site*
- 12 Watertight sealing mass*
- 13 Self-drilling screw with a seal
- 14 UD42 seal
- 15 102 flashing

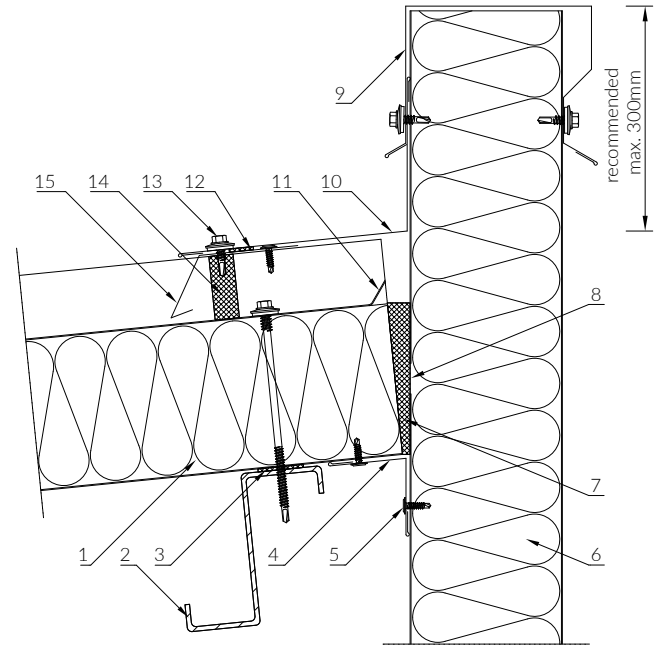

Drawing 54

ROOF PANEL AND WALL PANEL JOINT
ROOF SIDE - WALL

- 1 PaNELTECH wall sandwich panel
- 2 O20 flashing
- 3 Thermal insulation
- 4 Facing cutting executed at the construction site*
- 5 Watertight sealing mass
- 6 Self-drilling screw or blind rivet
- 7 118 flashing
- 8 Facing bending executed at the construction site
- 9 121 flashing
- 10 114 flashing
- 11 Self-drilling screw with a seal
- 12 PaNELTECH roof sandwich panel

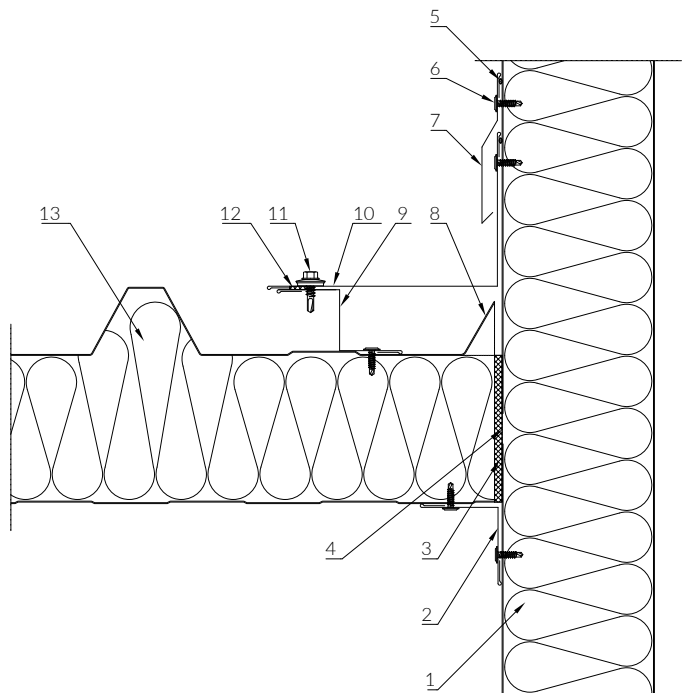

Drawing 55

* as required

ROOF PANEL AND WALL JOINT

SINGLE-SLOPED ROOF - MASONRY WALL

- 1 PaNELTECH roof sandwich panel
- 2 Construction in accordance with building design
- 3 Self adhesive sealant*
- 4 Self-drilling screw or blind rivet
- 5 O20 flashing
- 6 Masonry wall
- 7 Watertight sealing mass
- 8 119 flashing
- 9 Thermal insulation
- 10 115 flashing
- 11 Watertight sealing mass*
- 12 Self-drilling screw with a seal
- 13 UD42 seal
- 14 102 flashing

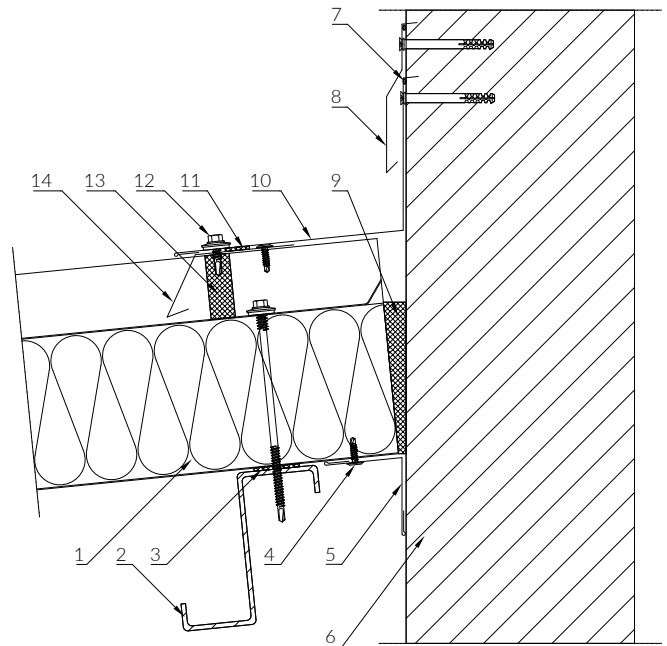

Drawing 56

ROOF DRAINAGE GUTTER

- 1 External load-bearing profile
- 2 Thermal insulation of the drainage gutter
- 3 Watertight insulation (e.g. PVC membrane or EPDM)
- 4 Drainage gutter heating installation*
- 5 Overflow outlet
- 6 Watertight sealing mass
- 7 Z42 roof end cap (recommended for flat roofs and PWW-D panels)
- 8 Self-drilling screw with a seal
- 9 PaNELTECH roof sandwich panel
- 10 Fastener
- 11 Self adhesive sealant*
- 12 Construction in accordance with building design
- 13 Self-drilling screw or blind rivet
- 14 Flashing with PVC coating
- 15 Watertight insulation weld
- 16 110 flashing / B =120

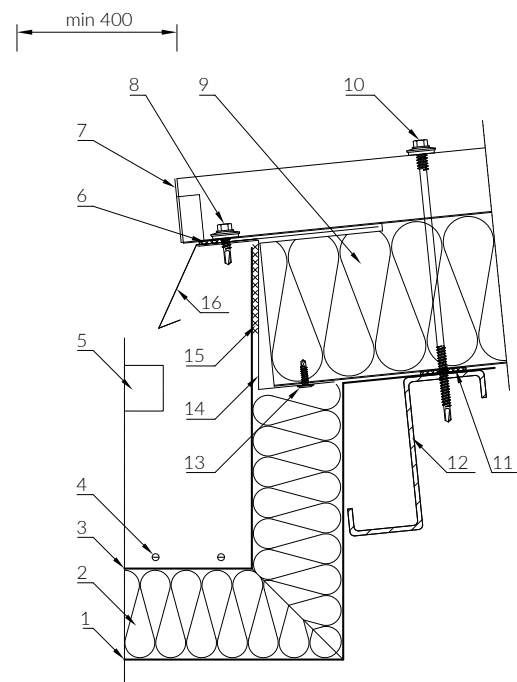

Drawing 57

* as required

ROOF PANEL AND SKYLIGHT JOINT

- 1 PaNELTECH roof sandwich panel
- 2 Construction in accordance with building design
- 3 Self adhesive sealant*
- 4 Fastener
- 5 Skylight base thermal insulation
- 6 Skylight base
- 7 Roof skylight
- 8 Skylight flashing
- 9 Self-drilling screw or blind rivet
- 10 Watertight sealing mass / self adhesive sealant*
- 11 Self-drilling screw with a seal
- 12 UD42 seal
- 13 102 flashing

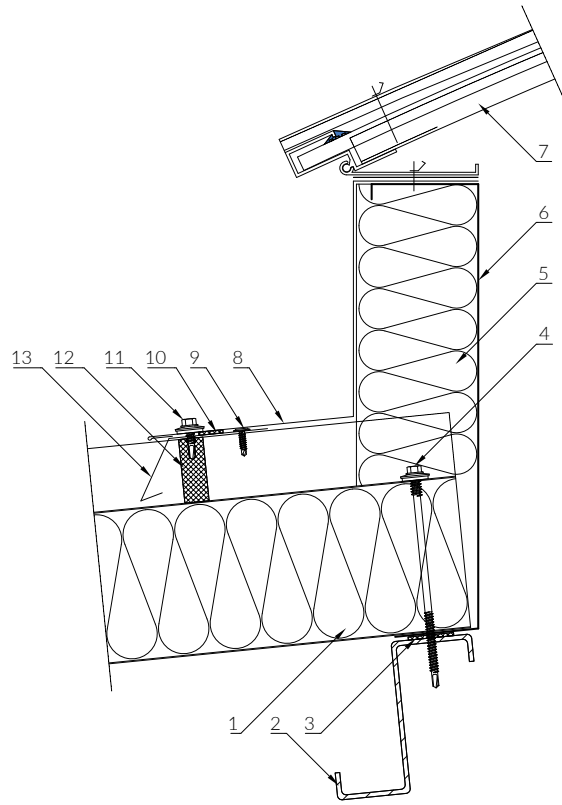

Drawing 58

ROOF PANEL AND SKYLIGHT JOINT

- 1 PaNELTECH roof sandwich panel
- 2 Self adhesive sealant*
- 3 Construction in accordance with building design
- 4 Fastener
- 5 Skylight base thermal insulation
- 6 Skylight base
- 7 Roof skylight
- 8 Watertight insulation (PVC membrane or EPDM)
- 9 Leveling element (e.g. PIR SOFT LE)

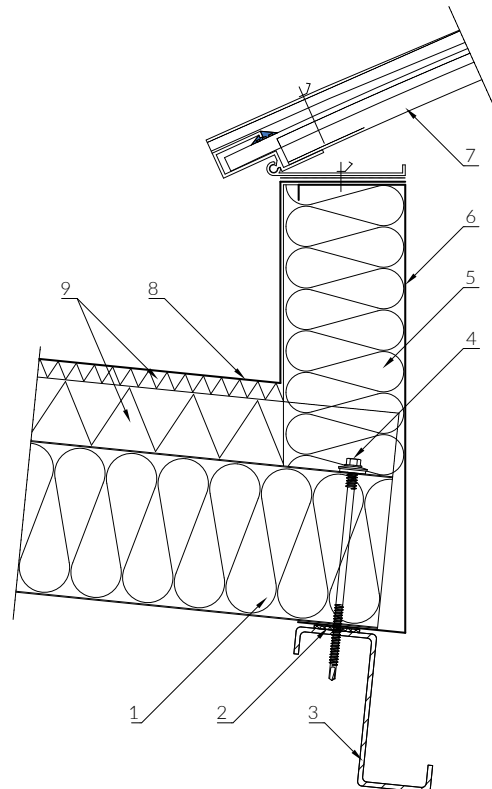

Drawing 59

* as required

The technical solutions presented in this Technical Catalog are for reference only and require further consultations with the designer. Paneltech hereby waives any responsibility for errors resulting from the incorrect use of information presented in this Catalog.

The catalog shall not constitute an offer within the meaning of the Civil Code. Paneltech Sp. z o.o. reserves the right to introduce changes without notification.

Detailed information (including panel layout and support spans) can be found in the General Terms and Conditions of Sale available at paneltech.pl.





PaNELTECH Sp. z o.o.
41-508 Chorzów
ul. Michałkowicka 24
+48 32 245 91 41
info@paneltech.pl

PANELTECH.PL